

Formal Specification and Verification of Fully Asynchronous Implementations of the Data Encryption Standard

Wendelin Serwe

Inria

Univ. Grenoble Alpes, LIG, F-38000 Grenoble, France

CNRS, LIG, F-38000 Grenoble, France

wendelin.serwe@inria.fr

This paper presents two formal models of the Data Encryption Standard (DES), a first using the international standard LOTOS, and a second using the more recent process calculus LNT. Both models encode the DES in the style of asynchronous circuits, i.e., the data-flow blocks of the DES algorithm are represented by processes communicating via rendezvous. To ensure correctness of the models, several techniques have been applied, including model checking, equivalence checking, and comparing the results produced by a prototype automatically generated from the formal model with those of existing implementations of the DES. The complete code of the models is provided as appendices and also available on the website of the CADP verification toolbox.

1 Introduction

The Data Encryption Standard (DES) is a symmetric-key encryption algorithm, that has been for almost 30 years a Federal Information Processing Standard [17]. At present, the main weakness of the algorithm is its use of keys of 56 bits, which are too short to withstand brute force attacks. To address this issue, the Triple Data Encryption Algorithm (TDEA or Triple DES) variant [18] applies the DES algorithm three times (encryption, decryption, encryption), using three different keys, and is still an approved symmetric cryptographic algorithm for 8-byte block ciphers, e.g., for secure payment systems [4, Annex B1.1].

An interesting aspect of the DES is that it is specified by a data-flow diagram, i.e., as a set of blocks communicating by message passing. Such an architecture is naturally asynchronous because there is no need for a global clock synchronizing these various blocks. Due to different interleavings of the block executions, there exists a risk that the DES execution produces a nondeterministic result, although this is not expected. This problem naturally lends itself to analysis with process calculi.

A prior case-study [1] analyzed an asynchronous circuit¹ implementing the DES. This circuit was specified in the CHP (Communicating Hardware Processes) [13] process calculus, which was translated into the IF [2] formalism, and subsequently verified using the CADP toolbox [8]², i.e., the corresponding state space was generated as an LTS (Labeled Transition System) and several properties were verified by model and equivalence checking. To reduce the state space, this prior case-study replaced some of the parallelism by sequential compositions, removing some asynchronism.

The present paper goes further and analyzes the fully asynchronous DES, describing formal models of the DES in two different process calculi, namely the international standard LOTOS [12] and the

¹An asynchronous circuit is a circuit without clocks, where the different components of the circuit synchronize via handshake protocols. Implementing a cryptographic algorithm as an asynchronous circuit makes it more robust against side channel attacks based on the analysis of the power consumption or radio-emission, which have significantly fewer peaks that could be exploited to get information about the key or data being encrypted [15].

²<http://cadp.inria.fr>

more recent LNT language [3], both supported by CADP. The LOTOS model of the DES was directly derived from the DES standard [17] to experiment with the application of LOTOS for the analysis of asynchronous circuits. In August 2015, the LOTOS model was rewritten into an equivalent LNT model to fulfill the expectations of the MARS workshop. Both models have been analyzed using different techniques, namely data abstraction, model checking, equivalence checking, and the automatic generation of a prototype software implementation. All these verification steps have been automated by an SVL (Script Verification Language) [6] script.

The rest of this paper is organized as follows. Section 2 briefly presents the data-flow architecture of the DES. Section 3 discusses modeling challenges and choices. Section 4 (respectively, 5) presents the steps undertaken to assess the correctness of the model with (respectively without) data abstraction. Section 6 gives concluding remarks. Appendix A is the complete source code of the LNT model. Appendix B is the complete source code of the LOTOS model. Appendix C contains the C code required to generate a prototype with the EXEC/CÆSAR framework. Appendix D provides the SVL script to execute the verification scenarios described in this paper.

2 Architecture of the Asynchronous Data Encryption Standard

The DES is an iterative algorithm, which takes as input a 64-bit word³ of data, a 64-bit key (from which only 56 bits are used), and a bit indicating whether the data is to be encrypted or decrypted, and produces as output a 64-bit word of encrypted or decrypted data. The DES first applies an initial permutation on the input data, splits the 64-bit data word into two 32-bit data words, named L_0 and R_0 , and then iteratively computes $L_{n+1} = R_n$ and $R_{n+1} = L_n \oplus f(R_n, K_{n+1})$, where \oplus stands for the bit-wise sum, and f is the so-called *cipher function*. The final result is obtained as the inverse initial permutation applied to the concatenation of R_{16} and L_{16} .

In each iteration, the cipher function f first applies a function named E to expand the 32-bit word R_n to a 48-bit word, and then computes the bit-wise sum with the 48-bit subkey K_n . The result is split into eight 6-bit words, each of which is transformed by a so-called S-box into a 4-bit word. The output of the cipher function is the concatenation of these eight 4-bit words, permuted by a function named P.

To compute the sixteen subkeys K_n (with $n \in \{1, \dots, 16\}$), a function named PC1 (permuted choice) selects 56 bits from the 64-bit key, and then splits the result into two 28-bit words, named C_0 and D_0 . For iteration n , the subkey K_n is obtained by application of a function named PC2 to select 48 bits from $C_n D_n$, which are defined by successive shift operations according to a schedule defined in the standard. Decryption follows the same scheme, only applying the subkeys in the opposite order.

3 Formal Models of the Asynchronous Data Encryption Standard

Figure 1 shows the overall architecture of the LOTOS and LNT models, which closely follow the architecture of the standard. Each block (permutation, S-box, bit-wise sum, shift, etc.) is represented by a process, communicating by rendezvous with its neighbors. Thus, there is no need for a global clock: each block waits for its operands, performs its operation, and transmits the result to the subsequent block.

In addition to the processes with a direct correspondence to blocks of the DES standard, the models include ten processes without a direct correspondence, but required to share blocks (or processes) among

³Longer data must be split into 64-bit words, possibly adding zeros at the end so that the total number of bits is a multiple of 64. Each 64-bit word is then encrypted or decrypted separately.

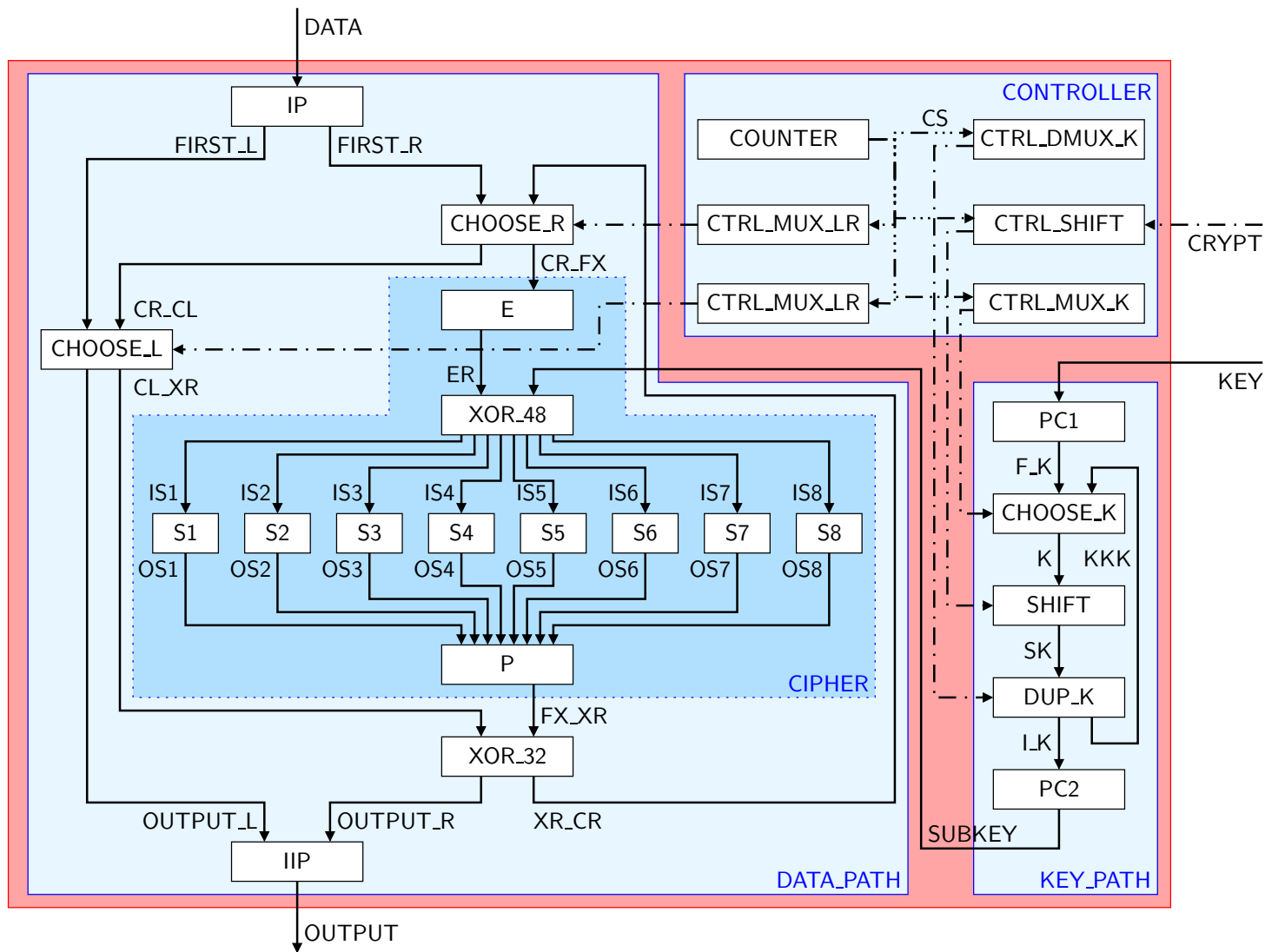

Figure 1: Architecture of the asynchronous Data Encryption Standard. Boxes represent processes, and arrows indicate synchronizations (dashed arrows correspond to the control signals). Arrows are labeled by the name of the corresponding gate, where F_K stands for FIRST_K, and I_K stands for INTERMEDIATE_K.

all iterations of the algorithm: the six processes of the CONTROLLER, and the four processes CHOOSE_L, CHOOSE_R, CHOOSE_K, and DUP_K. The latter four are arbiters and/or multiplexers, which select among several inputs and possibly duplicate their output.

The process COUNTER generates the control signal “CS !*i*”, where *i* starts from 0 and is increased up to 16, thus indicating seventeen steps (one more than the number of iterations in the algorithm). The signal CS is sent to the five other processes of the CONTROLLER, which in turn indicate to the shift register the number and direction of the shift(s) and to the four arbiters which input to read from and/or which output to write to. Seventeen steps are required because the processes CHOOSE_L and CHOOSE_R take as input either the initial data or the result of the previous iteration, and output either to the next iteration or the final output. Hence it is necessary to execute them before and after the sixteen iterations, explaining the additional step. Precisely, the rendezvous “CS !16” triggers a rendezvous only in process CTRL_MUX_LR, whereas it is simply consumed by CTRL_MUX_K, CTRL_DMUX_K, and CTRL_SHIFT.

Notice that the formal models contain no non-deterministic choice (**select** operator of LNT or “[]” operator of LOTOS), because every block of the DES is deterministic.

The complete LOTOS and LNT models are given as appendices and also available on the CADP website⁴. Table 1 gives the number of lines for the two models, plus those of the LOTOS model generated by the LNT2LOTOS translator from the LNT model. The LNT model is significantly shorter and syntactically closer to the DES standard. In particular, the definition of the S-boxes using tables (as in the standard) is more convenient, due to the automatically defined functions to manipulate arrays. Compared to the hand-written models, the generated LOTOS model is much larger due to many automatically generated functions and auxiliary processes that are “inlined” in the hand-written models.

Rewriting the LOTOS model into LNT uncovered a few errors in the LOTOS definitions of the S-boxes and a small bug⁵ in the LNT2LOTOS translator. This rewrite also showed that the controller was too restrictive. Precisely, the five control processes (CTRL_MUX_K, CTRL_SHIFT, CTRL_DMUX_K, and the two instances of CTRL_MUX_LR) were synchronized at the end of an encoding or decoding, although CTRL_SHIFT could accept a new input on gate CRYPT as soon as the shift-command for the generation of the last subkey has been sent to the shift register.⁶

4 Analysis of the Abstract Model

Analyzing the DES with enumerative techniques is challenging, because it is unfeasible to enumerate all 64-bit vectors. A first approach is to abstract from the actual *data* values and to focus the analysis on the control part, e.g., check whether the sixteen iterations are correctly synchronized. Redefining the BIT data type to contain a single value (instead of two values), automatically transforms all bit-vector types into singleton types and all functions operating on bit vectors to the identity function.⁷ Due to this drastic abstraction, enumerating all possible inputs is trivial, enabling LTS generation without resorting to environments and compositional techniques [7].

⁴http://cadp.inria.fr/demos/demo_38

⁵See entry #2076 in the list of changes to CADP (<http://cadp.inria.fr/changes.html>).

⁶Removing this unnecessary synchronization (also present in the CHP and IF models) slightly increases the LTS size: the initial LOTOS model yielded an LTS with 588,785,433 states and 5,512,418,012 transitions.

⁷The IF model [1] used a similar abstraction.

⁸The significantly smaller size (5.3 million states and 30 million transitions) of the LTS corresponding to the IF model [1] is explained by the fact that in the IF model the eight S-boxes execute sequentially rather than in parallel [16, page 305, footnote 4]. Applying a similar restriction to the LNT model, the size of the corresponding LTS drops to 1,375,048 states and 7,804,352 transitions (respectively to 8,183,770 states and 45,025,227 transitions for a restricted LOTOS model). A further difference is

	LOTOS	LNT	gen. LOTOS
types & functions	1172	575	2514
channels	0	50	58
processes	671	668	772
<i>total</i>	<i>1843</i>	<i>1293</i>	<i>3344</i>

Table 1: Line number count of the models

	LOTOS	LNT
states	591,914,192	167,300,852
transitions	5,542,917,498	1,500,073,686
time (min)	228	66
RAM (GB)	19.13	4.93

Table 2: Direct LTS Generation
(on an Xeon(R) E5-2630 at 2.4 GHz)⁸

Direct LTS Generation and Equivalence between the LNT and LOTOS Models. Table 2 gives statistics about the LTSs generated directly from the abstract models. The two models (LOTOS and LNT) yield LTSs equivalent for branching (but not strong) bisimulation (checked by PROPERTY_7 of the SVL script given in Appendix D). In both cases, the LTS minimized for branching bisimulation has 28 states and 78 transitions.

The significant difference in LTS size between the LNT model and the LOTOS model is explained by the semantic difference in the symmetric sequential composition [5]. The LOTOS operator “>>” generates an internal “i” transition, whereas the LNT operator “;” does not. Such a symmetric sequential composition (rather than a simple action prefix) is required whenever a process can read several inputs in parallel before producing its output. This is in particular the case for process P, which reads the output of the eight S-boxes. When these internal “i” transitions are removed by adding the pragma “(*! atomic *)” to all occurrences of “>>”, the LOTOS model yields an LTS of exactly the same size as the LNT model.

The LTS obtained after removing all offers (using appropriate renaming operations, i.e., those applied to file `des_sample.bcg` in PROPERTY_6 of the SVL script given in Appendix D) and minimization using branching bisimulation is shown in Figure 2.

Compositional LTS Generation. Compositional LTS generation, i.e., the bottom-up LTS construction alternating generation and minimization steps, is much more efficient. The initial steps of the SVL script given in Appendix D require at most 50 MB of RAM and generate the minimized LTS (28 states and 78 transitions) in less than 90 seconds. The success of compositional techniques on the LOTOS model triggered the development of the CHP2LOTOS translator [10] to provide the full power of CADP to the designers of asynchronous circuits.

Model Checking. Several properties of the control part have been analyzed formally, using model checking and equivalence checking on the LTS generated compositionally from the abstract models.

A first property, called PROPERTY_1 in the SVL script, expresses the absence of deadlocks.

A second property, called PROPERTY_2 expresses the fact that a triplet of inputs on gates CRYPT, DATA, and KEY is eventually followed by an rendezvous on gate OUTPUT.

A third property, called PROPERTY_3, describes the asynchronism of the DES models, i.e., that the DES may accept the inputs for N future rounds before it produces the result of the current round. This property is expressed by two temporal logic formulæ, a first one expressing that the DES never accepts more than N inputs in advance, and a second one expressing that there exists an execution, where the DES indeed accepts N inputs in advance. This third property is parametric, because N varies for the three inputs DATA, CRYPT, and KEY.

A last property, called PROPERTY_4, expresses the correct synchronization between the data path and the key path, namely that each encoding or decoding executes the sixteen iterations. This property can

that the controller in the IF model is a single automaton and enforces a stronger ordering between the inputs and outputs than the more asynchronous architecture shown in Figure 1.

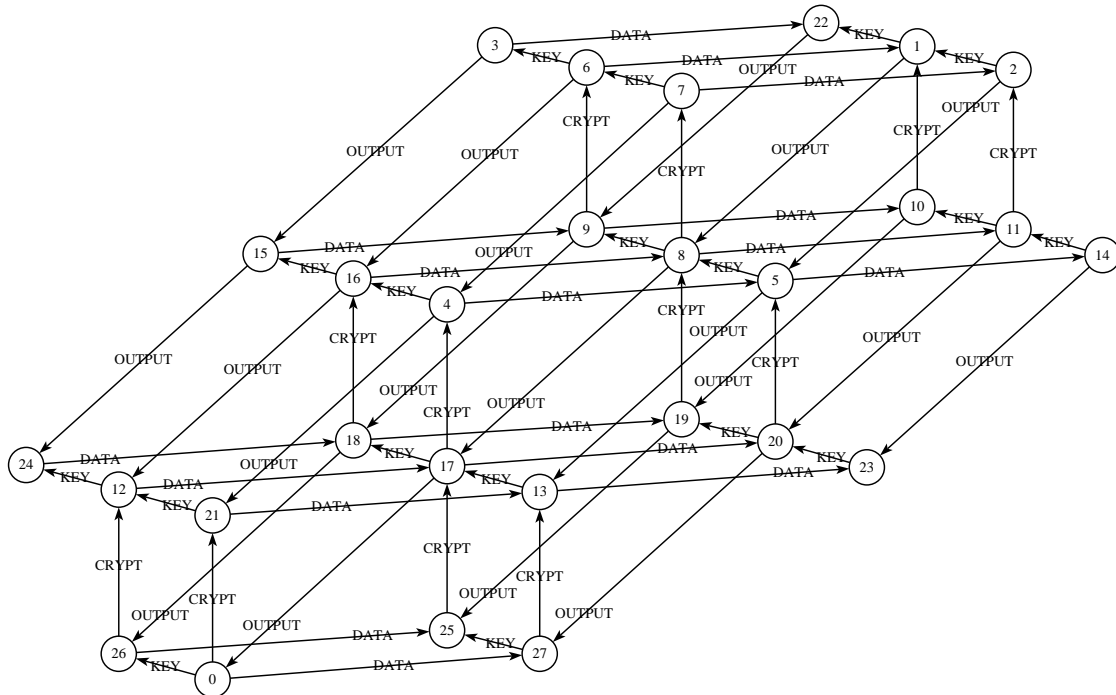

Figure 2: LTS of the abstract DES. All offers have been stripped from the transition labels. Thus, a transition labeled with CRYPT represents two transitions, labeled “CRYPT !false” and “CRYPT !true”. For all other transitions, the offer corresponds to the single value in the domain of abstract 64-bit vectors.

be verified in two ways: by model checking a temporal logic formula and by checking the equivalence of the generated labeled transition system with a simple automaton containing a loop of sixteen SUBKEY transitions (because there must be a subkey per iteration) interleaved with a CRYPT transition (because each encoding or decoding requires one such transition). The LNT (respectively, LOTOS) model of this automaton is given in Appendix A.13 (respectively, B.14). Notice that this verification requires to keep the SUBKEY gate visible.

5 Analysis of the Concrete Model

The concrete models (i.e., without data abstraction) can be used to check the correctness of the results computed by the DES. Two different approaches were used: model checking and the generation of a prototype implementation.

Rapid Prototyping. Using the EXEC/CÆSAR framework [11] for rapid prototyping, it is possible to generate a C implementation of the LOTOS or LNT model: one only has to provide C functions implementing the interaction with the environment on the visible gates CRYPT, DATA, KEY, and OUTPUT. This C code is given in Appendix C.

We first checked that the prototype is reversible, i.e., that deciphering a cipher with the same key results in the original data. These tests helped to spot and correct some errors in the subkey generation.

We also compared the results of the prototypes (LOTOS and LNT), and to those of some other publicly available implementations⁹. These comparisons helped to spot and correct a handful of differences

⁹See for instance https://www.schneier.com/books/applied_cryptography/source.html

caused by typographic errors, i.e., bad copying of the DES standard into LOTOS and LNT. The compilation and execution of the prototype implementation corresponds to PROPERTY_5 in the SVL script given in Appendix D. Although using a handful of tests is far from exhaustive, the structure of the DES with its iterations, permutations and bit operations and the fact that cipher heavily shuffles the input data lead to a coverage sufficient for the purpose of analyzing the *control* part.

Model Checking. The generation of an LTS from the concrete model requires an environment to restrict the domain of possible input values. The model DES_SAMPLE is such a variant of the concrete one, including a sequential environment providing a key and a data for a single encryption and checking the correctness of the output. The direct generation of the corresponding LTS (10,156,715 states and 75,933,635 transitions for the LNT model, and 32,219,740 states and 259,010,596 transitions for the LOTOS model) requires less than 6 GB of RAM.

The correctness of the computed result can be verified by model checking a property expressing that the action on gate OUTPUT is eventually reached. A second verification is that after removing all offers, the LTS is included in the LTS of Figure 2. These verifications are carried out by the PROPERTY_6 in the SVL script given in Appendix D.

6 Conclusion

This paper presents two formal models of the Data Encryption Standard, which might be an interesting benchmark example, because it is both complex and tractable (with current hardware and/or compositional techniques). For instance, it is sufficiently large to make interesting screenshots of the monitor of the distributed state space generation tool DISTRIBUTOR [9] (see also the DISTRIBUTOR manual page¹⁰). These models also illustrate an interesting feature of LOTOS and LNT, namely the possibility to easily change the implementation of a data type to transform a prototype implementation into an abstract model adapted to formal verification.

Acknowledgements. Some of the experiments presented in this paper were carried out using the Grid'5000 experimental testbed¹¹ built by Inria with support from CNRS, RENATER, several Universities, and other funding bodies. I am grateful to Hubert Garavel for his suggestion to improve the model(s) and their presentation. I would like to thank Edith Beigné, François Bertrand, Pascal Vivet (CEA Leti), Dominique Borrione, Menouer Boubekeur, Marc Renaudin (TIMA), and Gwen Salaün (Inria) for discussions about asynchronous logic, the CHP language, and the implementation of the DES in asynchronous logic.

References

- [1] Dominique Borrione, Menouer Boubekeur, Laurent Mounier, Marc Renaudin & Antoine Sirianni (2006): *Validation of Asynchronous Circuit Specifications using IF/CADP*. In: *VLSI-SOC: From Systems to Chip, Selected papers from the IFIP Conference on Very Large Scale Integration of System-on-Chip (VLSI-SoC'03)*, 200, International Federation for Information Processing, pp. 85–100, doi:10.1007/0-387-33403-3_6.
- [2] Marius Bozga, Jean-Claude Fernandez, Lucian Ghirvu, Susanne Graf, Jean-Pierre Krimm & Laurent Mounier (1999): *IF: An Intermediate Representation and Validation Environment for Timed Asynchronous*

¹⁰<http://cadp.inria.fr/man/distributor.html#sect7>

¹¹See <http://www.grid5000.fr>

- Systems*. In: *Proceedings of World Congress on Formal Methods in the Development of Computing Systems (FM'99)*, Toulouse, France, Springer Verlag, doi:10.1007/3-540-48119-2_19.
- [3] David Champelovier, Xavier Clerc, Hubert Garavel, Yves Guerte, Christine McKinty, Vincent Powazny, Frédéric Lang, Wendelin Serwe & Gideon Smeding (2015): *Reference Manual of the LNT to LOTOS Translator (Version 6.3)*. Available at <http://cadp.inria.fr/publications/Champelovier-Clerc-Garavel-et-al-10.html>. INRIA/VASY and INRIA/CONVECS, 135 pages.
- [4] EMVCo (2011): *EMV Specification 4.3, Book 2, Security and Key Management*. Technical Report.
- [5] Hubert Garavel (2015): *Revisiting Sequential Composition in Process Calculi*. *Journal of Logical and Algebraic Methods in Programming* 84(6), pp. 742–762, doi:10.1016/j.jlamp.2015.08.001.
- [6] Hubert Garavel & Frédéric Lang (2001): *SVL: a Scripting Language for Compositional Verification*. In: *Proceedings of the 21st IFIP WG 6.1 International Conference on Formal Techniques for Networked and Distributed Systems (FORTE'01)*, Cheju Island, Korea, Kluwer Academic Publishers, pp. 377–392, doi:10.1007/0-306-47003-9_24. Available at <http://cadp.inria.fr/publications/Garavel-Lang-01.html>.
- [7] Hubert Garavel, Frédéric Lang & Radu Mateescu (2015): *Compositional Verification of Asynchronous Concurrent Systems Using CADP*. *Acta Informatica* 52(4), pp. 337–392, doi:10.1007/s00236-015-0226-1. Available at <http://cadp.inria.fr/publications/Garavel-Lang-Mateescu-15.html>.
- [8] Hubert Garavel, Frédéric Lang, Radu Mateescu & Wendelin Serwe (2013): *CADP 2011: A Toolbox for the Construction and Analysis of Distributed Processes*. *Springer International Journal on Software Tools for Technology Transfer (STTT)* 15(2), pp. 89–107, doi:10.1007/s10009-012-0244-z. Available at <http://cadp.inria.fr/publications/Garavel-Lang-Mateescu-Serwe-13.html>.
- [9] Hubert Garavel, Radu Mateescu, Damien Bergamini, Adrian Curic, Nicolas Descoubes, Christophe Joubert, Irina Smarandache-Sturm & Gilles Stragier (2006): *DISTRIBUTOR and BCG_MERGE: Tools for Distributed Explicit State Space Generation*. In: *Proceedings of the 12th International Conference on Tools and Algorithms for the Construction and Analysis of Systems TACAS'2006 (Vienna, Austria)*, *Lecture Notes in Computer Science* 3920, Springer Verlag, pp. 445–449, doi:10.1007/11691372_30. Available at <http://cadp.inria.fr/publications/Garavel-Mateescu-Bergamini-et-al-06.html>.
- [10] Hubert Garavel, Gwen Salaün & Wendelin Serwe (2009): *On the Semantics of Communicating Hardware Processes and their Translation into LOTOS for the Verification of Asynchronous Circuits with CADP*. *Science of Computer Programming* 74(3), pp. 100–127, doi:10.1016/j.scico.2008.09.011. Available at <http://cadp.inria.fr/publications/Garavel-Salaun-Serwe-09.html>.
- [11] Hubert Garavel, César Viho & Massimo Zendri (2001): *System Design of a CC-NUMA Multiprocessor Architecture using Formal Specification, Model-Checking, Co-Simulation, and Test Generation*. *Springer International Journal on Software Tools for Technology Transfer (STTT)* 3(3), pp. 314–331, doi:10.1007/s100090100044. Available at <http://cadp.inria.fr/publications/Garavel-Viho-Zendri-00.html>.
- [12] ISO/IEC (1989): *LOTOS — A Formal Description Technique Based on the Temporal Ordering of Observational Behaviour*. International Standard 8807, International Organization for Standardization — Information Processing Systems — Open Systems Interconnection, Geneva.
- [13] Alain J. Martin (1986): *Compiling Communicating Processes into Delay-Insensitive VLSI Circuits*. *Distributed Computing* 1(4), pp. 226–234, doi:10.1007/BF01660034.
- [14] Radu Mateescu & Damien Thivolle (2008): *A Model Checking Language for Concurrent Value-Passing Systems*. In: *Proceedings of the 15th International Symposium on Formal Methods (FM'08)*, Turku, Finland, *Lecture Notes in Computer Science* 5014, Springer Verlag, pp. 148–164, doi:10.1007/978-3-540-68237-0_12. Available at <http://cadp.inria.fr/publications/Mateescu-Thivolle-08.html>.
- [15] Simon Moore, Ross Anderson, Paul Cunningham, Robert Mullins & George Taylor (2002): *Improving Smart Card Security using Self-timed Circuits*. In: *Proceedings of the Eighth International Symposium on Asyn-*

chronous Circuits and Systems (ASYNC'02), Manchester, United Kingdom, IEEE, pp. 211–218, doi:10.1109/ASYNC.2002.1000311.

- [16] Gwen Salaün & Wendelin Serwe (2005): *Translating Hardware Process Algebras into Standard Process Algebras — Illustration with CHP and LOTOS*. In: *Proceedings of the 5th International Conference on Integrated Formal Methods (IFM'05)*, Eindhoven, The Netherlands, *Lecture Notes in Computer Science 3771*, Springer Verlag, doi:10.1007/11589976_17. Available at <http://cadp.inria.fr/publications/Salaun-Serwe-05.html>.
- [17] National Institute of Standards & Technology (1999): *Data Encryption Standard (DES)*. Federal Information Processing Standards Publication 46-3. Available at <http://csrc.nist.gov/publications/fips/fips46-3/fips46-3.pdf>.
- [18] National Institute of Standards & Technology (2012): *Recommendation for the Triple Data Encryption Algorithm (TDEA) Block Cipher*. NIST Special Publication 800-67, Revision 1. Available at <http://csrc.nist.gov/publications/nistpubs/800-67-Rev1/SP-800-67-Rev1.pdf>.

A LNT Model of an Asynchronous DES

This appendix gives the complete LNT model of the DES, as required by the SVL verification scenario given in Appendix D. This model requires CADP version 2015-h “Stony Brook” (August 2015) or later. The syntax and semantics of LNT is defined in the reference manual [3].

A.1 Module BIT_CONCRETE

```

module BIT_CONCRETE is

type BIT is
  — bit data type with two different values
  0 !implementedby "BIT_ZERO" ,
  1 !implementedby "BIT_ONE"
  with "=="
end type

end module

```

A.2 Module BIT_ABSTRACT

This module defines the abstraction replacing the concrete implementation of type BIT (see module BIT_CONCRETE.lnt above), transforming the two-valued type into a singleton, which transitively transforms all bit vectors into singletons as well, thus completely abstracting data.

```

module BIT_ABSTRACT is

type BIT is
  — bit data type abstracted to a single value
  0
  with "=="
end type

function 1 : BIT is
  return 0
end function

```

end module

A.3 Module TYPES

module TYPES (BIT) **with** "get" **is**

— exclusive-or operation on (abstract or concrete) bits

```
function _xor_ (X, Y : BIT) : BIT is
  if X == Y then
    return 0
  else
    return 1
  end if
end function
```

— data type for counting the iterations of the algorithm

```
type ITERATION is
  range 0 .. 16 of NAT
  with "=", "!=", "first", "last"
end type
```

— data type for the controlling the behavior of the shift register

```
type SHIFT is
  NO, — no shift
  LS1, — 1 left shift
  LS2, — 2 left shifts
  RS1, — 1 right shift
  RS2 — 2 right shifts
  with "="
end type
```

— data type for the control signals used for the multiplexers

```
type PHASE is
  F, — first iteration
  N, — intermediate iteration
  L — last iteration
  with "="
end type
```

— 2-bit vectors

```

type BIT2 is
  MK_2 (B1, B2: BIT)
end type

```

— conversion of a 2-bit vector into a natural number
— note: the most significant bit is B1

```

function BIT2_TO_NAT (X: BIT2) : NAT is
  var N: NAT in
    N := 0;
    if X.B1 == 1 then N := N + 2 end if;
    if X.B2 == 1 then N := N + 1 end if;
    return N
  end var
end function

```

— 4-bit vectors

```

type BIT4 is !implementedby "ADT_BIT4"
  MK_4 (B1, B2, B3, B4: BIT) !implementedby "MK_4"
end type

```

— conversion of a 4-bit vector into a natural number
— note: the most significant bit is B1

```

function BIT4_TO_NAT (X: BIT4) : NAT is
  var N: NAT in
    N := 0;
    if X.B1 == 1 then N := N + 8 end if;
    if X.B2 == 1 then N := N + 4 end if;
    if X.B3 == 1 then N := N + 2 end if;
    if X.B4 == 1 then N := N + 1 end if;
    return N
  end var
end function

```

— conversion of a natural number into a 4-bit vector
— note: the most significant bit is B1

```

function NAT_TO_BIT4 (N: NAT) : BIT4 is
  case N in
    0    → return MK_4 (0, 0, 0, 0)
  | 1    → return MK_4 (0, 0, 0, 1)
  | 2    → return MK_4 (0, 0, 1, 0)
  | 3    → return MK_4 (0, 0, 1, 1)
  | 4    → return MK_4 (0, 1, 0, 0)
  | 5    → return MK_4 (0, 1, 0, 1)
  | 6    → return MK_4 (0, 1, 1, 0)

```

```

| 7      -> return MK_4 (0, 1, 1, 1)
| 8      -> return MK_4 (1, 0, 0, 0)
| 9      -> return MK_4 (1, 0, 0, 1)
| 10     -> return MK_4 (1, 0, 1, 0)
| 11     -> return MK_4 (1, 0, 1, 1)
| 12     -> return MK_4 (1, 1, 0, 0)
| 13     -> return MK_4 (1, 1, 0, 1)
| 14     -> return MK_4 (1, 1, 1, 0)
| any NAT -> return MK_4 (1, 1, 1, 1)
end case
end function

```

— *6-bit vectors*

```

type BIT6 is
  MK_6 (B1, B2, B3, B4, B5, B6: BIT)
end type

```

— *projection of 6-bit vectors to 2-bit vectors*

```

function 1AND6 (X: BIT6) : BIT2 is
  return MK_2 (X.B1, X.B6)
end function

```

— *projection of 6-bit vectors to 4-bit vectors*

```

function 2TO5 (X: BIT6) : BIT4 is
  return MK_4 (X.B2, X.B3, X.B4, X.B5)
end function

```

— *32-bit vectors*

```

type BIT32 is
  MK_32 (B1, B2, B3, B4, B5, B6, B7, B8,
         B9, B10, B11, B12, B13, B14, B15, B16,
         B17, B18, B19, B20, B21, B22, B23, B24,
         B25, B26, B27, B28, B29, B30, B31, B32: BIT)
end type

```

— *bitwise XOR for 32-bit vectors*

```

function XOR (A, B: BIT32) : BIT32 is
  return MK_32 (A.B1 xor B.B1, A.B2 xor B.B2,
               A.B3 xor B.B3, A.B4 xor B.B4,
               A.B5 xor B.B5, A.B6 xor B.B6,
               A.B7 xor B.B7, A.B8 xor B.B8,
               A.B9 xor B.B9, A.B10 xor B.B10,

```

```

A.B11 xor B.B11, A.B12 xor B.B12,
A.B13 xor B.B13, A.B14 xor B.B14,
A.B15 xor B.B15, A.B16 xor B.B16,
A.B17 xor B.B17, A.B18 xor B.B18,
A.B19 xor B.B19, A.B20 xor B.B20,
A.B21 xor B.B21, A.B22 xor B.B22,
A.B23 xor B.B23, A.B24 xor B.B24,
A.B25 xor B.B25, A.B26 xor B.B26,
A.B27 xor B.B27, A.B28 xor B.B28,
A.B29 xor B.B29, A.B30 xor B.B30,
A.B31 xor B.B31, A.B32 xor B.B32)

```

end function

— concatenation of eight 4-bit vectors to form a 32-bit vector

```

function MK_32 (V1, V2, V3, V4, V5, V6, V7, V8: BIT4) : BIT32 is
  return MK_32 (V1.B1, V1.B2, V1.B3, V1.B4, V2.B1, V2.B2, V2.B3, V2.B4,
    V3.B1, V3.B2, V3.B3, V3.B4, V4.B1, V4.B2, V4.B3, V4.B4,
    V5.B1, V5.B2, V5.B3, V5.B4, V6.B1, V6.B2, V6.B3, V6.B4,
    V7.B1, V7.B2, V7.B3, V7.B4, V8.B1, V8.B2, V8.B3, V8.B4)

```

end function

— 48-bit vectors

```

type BIT48 is
  MK_48 (B1, B2, B3, B4, B5, B6, B7, B8,
    B9, B10, B11, B12, B13, B14, B15, B16,
    B17, B18, B19, B20, B21, B22, B23, B24,
    B25, B26, B27, B28, B29, B30, B31, B32,
    B33, B34, B35, B36, B37, B38, B39, B40,
    B41, B42, B43, B44, B45, B46, B47, B48: BIT)

```

end type

— bitwise XOR for 48-bit vectors

```

function XOR (A, B: BIT48) : BIT48 is
  return MK_48 (A.B1 xor B.B1, A.B2 xor B.B2,
    A.B3 xor B.B3, A.B4 xor B.B4,
    A.B5 xor B.B5, A.B6 xor B.B6,
    A.B7 xor B.B7, A.B8 xor B.B8,
    A.B9 xor B.B9, A.B10 xor B.B10,
    A.B11 xor B.B11, A.B12 xor B.B12,
    A.B13 xor B.B13, A.B14 xor B.B14,
    A.B15 xor B.B15, A.B16 xor B.B16,
    A.B17 xor B.B17, A.B18 xor B.B18,
    A.B19 xor B.B19, A.B20 xor B.B20,
    A.B21 xor B.B21, A.B22 xor B.B22,
    A.B23 xor B.B23, A.B24 xor B.B24,
    A.B25 xor B.B25, A.B26 xor B.B26,

```

```

A.B27 xor B.B27, A.B28 xor B.B28,
A.B29 xor B.B29, A.B30 xor B.B30,
A.B31 xor B.B31, A.B32 xor B.B32,
A.B33 xor B.B33, A.B34 xor B.B34,
A.B35 xor B.B35, A.B36 xor B.B36,
A.B37 xor B.B37, A.B38 xor B.B38,
A.B39 xor B.B39, A.B40 xor B.B40,
A.B41 xor B.B41, A.B42 xor B.B42,
A.B43 xor B.B43, A.B44 xor B.B44,
A.B45 xor B.B45, A.B46 xor B.B46,
A.B47 xor B.B47, A.B48 xor B.B48)

```

end function

— projections of 48-bit vectors to 6-bit vectors

```

function 1TO6 (X: BIT48) : BIT6 is
  return MK_6 (X.B1, X.B2, X.B3, X.B4, X.B5, X.B6)
end function

```

```

function 7TO12 (X: BIT48) : BIT6 is
  return MK_6 (X.B7, X.B8, X.B9, X.B10, X.B11, X.B12)
end function

```

```

function 13TO18 (X: BIT48) : BIT6 is
  return MK_6 (X.B13, X.B14, X.B15, X.B16, X.B17, X.B18)
end function

```

```

function 19TO24 (X: BIT48) : BIT6 is
  return MK_6 (X.B19, X.B20, X.B21, X.B22, X.B23, X.B24)
end function

```

```

function 25TO30 (X: BIT48) : BIT6 is
  return MK_6 (X.B25, X.B26, X.B27, X.B28, X.B29, X.B30)
end function

```

```

function 31TO36 (X: BIT48) : BIT6 is
  return MK_6 (X.B31, X.B32, X.B33, X.B34, X.B35, X.B36)
end function

```

```

function 37TO42 (X: BIT48) : BIT6 is
  return MK_6 (X.B37, X.B38, X.B39, X.B40, X.B41, X.B42)
end function

```

```

function 43TO48 (X: BIT48) : BIT6 is
  return MK_6 (X.B43, X.B44, X.B45, X.B46, X.B47, X.B48)
end function

```

— 56-bit vectors

type BIT56 **is**

```

MK_56 (B1, B2, B3, B4, B5, B6, B7, B8,
      B9, B10, B11, B12, B13, B14, B15, B16,
      B17, B18, B19, B20, B21, B22, B23, B24,
      B25, B26, B27, B28, B29, B30, B31, B32,
      B33, B34, B35, B36, B37, B38, B39, B40,
      B41, B42, B43, B44, B45, B46, B47, B48,
      B49, B50, B51, B52, B53, B54, B55, B56: BIT)

```

```
end type
```

— *left shift of a 56-bit vector*

— *note: more precisely, parallel left shift of two 28-bit vectors*

```

function LSHIFT (X: BIT56) : BIT56 is
  return MK_56 (X.B2, X.B3, X.B4, X.B5, X.B6, X.B7, X.B8, X.B9,
                X.B10, X.B11, X.B12, X.B13, X.B14, X.B15, X.B16, X.B17,
                X.B18, X.B19, X.B20, X.B21, X.B22, X.B23, X.B24, X.B25,
                X.B26, X.B27, X.B28, X.B1, X.B30, X.B31, X.B32, X.B33,
                X.B34, X.B35, X.B36, X.B37, X.B38, X.B39, X.B40, X.B41,
                X.B42, X.B43, X.B44, X.B45, X.B46, X.B47, X.B48, X.B49,
                X.B50, X.B51, X.B52, X.B53, X.B54, X.B55, X.B56, X.B29)

```

```
end function
```

— *right shift of a 56-bit vector*

— *note: more precisely, parallel right shift of two 28-bit vectors*

```

function RSHIFT (X: BIT56) : BIT56 is
  return MK_56 (X.B28, X.B1, X.B2, X.B3, X.B4, X.B5, X.B6, X.B7,
                X.B8, X.B9, X.B10, X.B11, X.B12, X.B13, X.B14, X.B15,
                X.B16, X.B17, X.B18, X.B19, X.B20, X.B21, X.B22, X.B23,
                X.B24, X.B25, X.B26, X.B27, X.B56, X.B29, X.B30, X.B31,
                X.B32, X.B33, X.B34, X.B35, X.B36, X.B37, X.B38, X.B39,
                X.B40, X.B41, X.B42, X.B43, X.B44, X.B45, X.B46, X.B47,
                X.B48, X.B49, X.B50, X.B51, X.B52, X.B53, X.B54, X.B55)

```

```
end function
```

— *64-bit vectors*

```

type BIT64 is !implementedby "ADT_BIT64" !printedby "ADT_PRINT_BIT64"
  MK_64 (B1, B2, B3, B4, B5, B6, B7, B8,
        B9, B10, B11, B12, B13, B14, B15, B16,
        B17, B18, B19, B20, B21, B22, B23, B24,
        B25, B26, B27, B28, B29, B30, B31, B32,
        B33, B34, B35, B36, B37, B38, B39, B40,
        B41, B42, B43, B44, B45, B46, B47, B48,
        B49, B50, B51, B52, B53, B54, B55, B56,
        B57, B58, B59, B60, B61, B62, B63, B64: BIT)
  !implementedby "MK_64"
  with "=", "!="
end type

```

— *projections of 64-bit vectors to 32-bit vectors*

```

function 1TO32 (X: BIT64) : BIT32 is
  return MK_32 (X.B1, X.B2, X.B3, X.B4, X.B5, X.B6, X.B7, X.B8,
                X.B9, X.B10, X.B11, X.B12, X.B13, X.B14, X.B15, X.B16,
                X.B17, X.B18, X.B19, X.B20, X.B21, X.B22, X.B23, X.B24,
                X.B25, X.B26, X.B27, X.B28, X.B29, X.B30, X.B31, X.B32)
end function

```

```

function 33TO64 (X: BIT64) : BIT32 is
  return MK_32 (X.B33, X.B34, X.B35, X.B36, X.B37, X.B38, X.B39, X.B40,
                X.B41, X.B42, X.B43, X.B44, X.B45, X.B46, X.B47, X.B48,
                X.B49, X.B50, X.B51, X.B52, X.B53, X.B54, X.B55, X.B56,
                X.B57, X.B58, X.B59, X.B60, X.B61, X.B62, X.B63, X.B64)
end function

```

— *concatenation of sixteen 4-bit vectors to form a 64-bit vector*

```

function MK_64 (V1, V2, V3, V4, V5, V6, V7, V8,
                V9, V10, V11, V12, V13, V14, V15, V16: BIT4) : BIT64 is
  !implemented by "CONCAT_BIT4"
  return MK_64 (V1.B1, V1.B2, V1.B3, V1.B4,
                V2.B1, V2.B2, V2.B3, V2.B4,
                V3.B1, V3.B2, V3.B3, V3.B4,
                V4.B1, V4.B2, V4.B3, V4.B4,
                V5.B1, V5.B2, V5.B3, V5.B4,
                V6.B1, V6.B2, V6.B3, V6.B4,
                V7.B1, V7.B2, V7.B3, V7.B4,
                V8.B1, V8.B2, V8.B3, V8.B4,
                V9.B1, V9.B2, V9.B3, V9.B4,
                V10.B1, V10.B2, V10.B3, V10.B4,
                V11.B1, V11.B2, V11.B3, V11.B4,
                V12.B1, V12.B2, V12.B3, V12.B4,
                V13.B1, V13.B2, V13.B3, V13.B4,
                V14.B1, V14.B2, V14.B3, V14.B4,
                V15.B1, V15.B2, V15.B3, V15.B4,
                V16.B1, V16.B2, V16.B3, V16.B4)
end function

```

— *concatenation of two 32-bit vectors to form a 64-bit vector*

```

function MK_64 (V1, V2: BIT32) : BIT64 is
  return MK_64 (V1.B1, V1.B2, V1.B3, V1.B4,
                V1.B5, V1.B6, V1.B7, V1.B8,
                V1.B9, V1.B10, V1.B11, V1.B12,
                V1.B13, V1.B14, V1.B15, V1.B16,
                V1.B17, V1.B18, V1.B19, V1.B20,
                V1.B21, V1.B22, V1.B23, V1.B24,

```



```

V1.B25, V1.B26, V1.B27, V1.B28,
V1.B29, V1.B30, V1.B31, V1.B32,
V2.B1, V2.B2, V2.B3, V2.B4,
V2.B5, V2.B6, V2.B7, V2.B8,
V2.B9, V2.B10, V2.B11, V2.B12,
V2.B13, V2.B14, V2.B15, V2.B16,
V2.B17, V2.B18, V2.B19, V2.B20,
V2.B21, V2.B22, V2.B23, V2.B24,
V2.B25, V2.B26, V2.B27, V2.B28,
V2.B29, V2.B30, V2.B31, V2.B32)

```

end function

end module

A.4 Module PERMUTATION_FUNCTIONS

module PERMUTATION_FUNCTIONS (TYPES) **is**

— *E: expansion of a 32-bit vector to a 48-bit vector*

```

function E (X: BIT32) : BIT48 is
  return MK_48 (X.B32, X.B1, X.B2, X.B3, X.B4, X.B5,
    X.B4, X.B5, X.B6, X.B7, X.B8, X.B9,
    X.B8, X.B9, X.B10, X.B11, X.B12, X.B13,
    X.B12, X.B13, X.B14, X.B15, X.B16, X.B17,
    X.B16, X.B17, X.B18, X.B19, X.B20, X.B21,
    X.B20, X.B21, X.B22, X.B23, X.B24, X.B25,
    X.B24, X.B25, X.B26, X.B27, X.B28, X.B29,
    X.B28, X.B29, X.B30, X.B31, X.B32, X.B1)

```

end function

— *IP: initial permutation*

```

function IP (X: BIT64) : BIT64 is
  return MK_64 (X.B58, X.B50, X.B42, X.B34, X.B26, X.B18, X.B10, X.B2,
    X.B60, X.B52, X.B44, X.B36, X.B28, X.B20, X.B12, X.B4,
    X.B62, X.B54, X.B46, X.B38, X.B30, X.B22, X.B14, X.B6,
    X.B64, X.B56, X.B48, X.B40, X.B32, X.B24, X.B16, X.B8,
    X.B57, X.B49, X.B41, X.B33, X.B25, X.B17, X.B9, X.B1,
    X.B59, X.B51, X.B43, X.B35, X.B27, X.B19, X.B11, X.B3,
    X.B61, X.B53, X.B45, X.B37, X.B29, X.B21, X.B13, X.B5,
    X.B63, X.B55, X.B47, X.B39, X.B31, X.B23, X.B15, X.B7)

```

end function

— *IIP: inverse initial permutation*

```

function IIP (X: BIT64) : BIT64 is
  return MK_64 (X.B40, X.B8, X.B48, X.B16, X.B56, X.B24, X.B64, X.B32,
    X.B39, X.B7, X.B47, X.B15, X.B55, X.B23, X.B63, X.B31,

```

```

X.B38, X.B6, X.B46, X.B14, X.B54, X.B22, X.B62, X.B30,
X.B37, X.B5, X.B45, X.B13, X.B53, X.B21, X.B61, X.B29,
X.B36, X.B4, X.B44, X.B12, X.B52, X.B20, X.B60, X.B28,
X.B35, X.B3, X.B43, X.B11, X.B51, X.B19, X.B59, X.B27,
X.B34, X.B2, X.B42, X.B10, X.B50, X.B18, X.B58, X.B26,
X.B33, X.B1, X.B41, X.B9, X.B49, X.B17, X.B57, X.B25)

```

end function

— *P: permutation*

```

function P (X: BIT32) : BIT32 is
  return MK_32 (X.B16, X.B7, X.B20, X.B21,
    X.B29, X.B12, X.B28, X.B17,
    X.B1, X.B15, X.B23, X.B26,
    X.B5, X.B18, X.B31, X.B10,
    X.B2, X.B8, X.B24, X.B14,
    X.B32, X.B27, X.B3, X.B9,
    X.B19, X.B13, X.B30, X.B6,
    X.B22, X.B11, X.B4, X.B25)

```

end function

— *PC1: permuted choice 1*

```

function PC1 (X: BIT64) : BIT56 is
  return MK_56 (X.B57, X.B49, X.B41, X.B33, X.B25, X.B17, X.B9,
    X.B1, X.B58, X.B50, X.B42, X.B34, X.B26, X.B18,
    X.B10, X.B2, X.B59, X.B51, X.B43, X.B35, X.B27,
    X.B19, X.B11, X.B3, X.B60, X.B52, X.B44, X.B36,

    X.B63, X.B55, X.B47, X.B39, X.B31, X.B23, X.B15,
    X.B7, X.B62, X.B54, X.B46, X.B38, X.B30, X.B22,
    X.B14, X.B6, X.B61, X.B53, X.B45, X.B37, X.B29,
    X.B21, X.B13, X.B5, X.B28, X.B20, X.B12, X.B4)

```

end function

— *PC2: permuted choice 2*

```

function PC2 (X: BIT56) : BIT48 is
  return MK_48 (X.B14, X.B17, X.B11, X.B24, X.B1, X.B5,
    X.B3, X.B28, X.B15, X.B6, X.B21, X.B10,
    X.B23, X.B19, X.B12, X.B4, X.B26, X.B8,
    X.B16, X.B7, X.B27, X.B20, X.B13, X.B2,
    X.B41, X.B52, X.B31, X.B37, X.B47, X.B55,
    X.B30, X.B40, X.B51, X.B45, X.B33, X.B48,
    X.B44, X.B49, X.B39, X.B56, X.B34, X.B53,
    X.B46, X.B42, X.B50, X.B36, X.B29, X.B32)

```

end function

end module

A.5 Module S_BOX_FUNCTIONS

The LNT model directly encodes the S-box tables as two-dimensional arrays, requiring the definition of the additional data types ROW and S_BOX_ARRAY, together with accessor functions GET_ROW() and GET_COLUMN() and projection functions 1AND6() and 2TO5() (the latter are part of module TYPES (see Appendix A.3)).

```
module S_BOX_FUNCTIONS (TYPES) is
```

— data types defining a two-dimensional array to encode the S-boxes

```
type ROW is  
  array [0..15] of NAT  
end type
```

```
type S_BOX_ARRAY is  
  array [0..3] of ROW  
end type
```

```
function GET_ROW (X: BIT6) : NAT is  
  return BIT2_TO_NAT (1AND6 (X))  
end function
```

```
function GET_COLUMN (X: BIT6) : NAT is  
  return BIT4_TO_NAT (2TO5 (X))  
end function
```

```
function S1 : S_BOX_ARRAY is  
  return S_BOX_ARRAY  
    (ROW (14, 4, 13, 1, 2, 15, 11, 8, 3, 10, 6, 12, 5, 9, 0, 7),  
     ROW ( 0, 15, 7, 4, 14, 2, 13, 1, 10, 6, 12, 11, 9, 5, 3, 8),  
     ROW ( 4, 1, 14, 8, 13, 6, 2, 11, 15, 12, 9, 7, 3, 10, 5, 0),  
     ROW (15, 12, 8, 2, 4, 9, 1, 7, 5, 11, 3, 14, 10, 0, 6, 13))  
end function
```

```
function S2 : S_BOX_ARRAY is  
  return S_BOX_ARRAY  
    (ROW (15, 1, 8, 14, 6, 11, 3, 4, 9, 7, 2, 13, 12, 0, 5, 10),  
     ROW ( 3, 13, 4, 7, 15, 2, 8, 14, 12, 0, 1, 10, 6, 9, 11, 5),  
     ROW ( 0, 14, 7, 11, 10, 4, 13, 1, 5, 8, 12, 6, 9, 3, 2, 15),  
     ROW (13, 8, 10, 1, 3, 15, 4, 2, 11, 6, 7, 12, 0, 5, 14, 9))  
end function
```

```

function S3 : S_BOX_ARRAY is
  return S_BOX_ARRAY
    (ROW (10, 0, 9, 14, 6, 3, 15, 5, 1, 13, 12, 7, 11, 4, 2, 8),
     ROW (13, 7, 0, 9, 3, 4, 6, 10, 2, 8, 5, 14, 12, 11, 15, 1),
     ROW (13, 6, 4, 9, 8, 15, 3, 0, 11, 1, 2, 12, 5, 10, 14, 7),
     ROW ( 1, 10, 13, 0, 6, 9, 8, 7, 4, 15, 14, 3, 11, 5, 2, 12))
end function

```

```

function S4 : S_BOX_ARRAY is
  return S_BOX_ARRAY
    (ROW ( 7, 13, 14, 3, 0, 6, 9, 10, 1, 2, 8, 5, 11, 12, 4, 15),
     ROW (13, 8, 11, 5, 6, 15, 0, 3, 4, 7, 2, 12, 1, 10, 14, 9),
     ROW (10, 6, 9, 0, 12, 11, 7, 13, 15, 1, 3, 14, 5, 2, 8, 4),
     ROW ( 3, 15, 0, 6, 10, 1, 13, 8, 9, 4, 5, 11, 12, 7, 2, 14))
end function

```

```

function S5 : S_BOX_ARRAY is
  return S_BOX_ARRAY
    (ROW ( 2, 12, 4, 1, 7, 10, 11, 6, 8, 5, 3, 15, 13, 0, 14, 9),
     ROW (14, 11, 2, 12, 4, 7, 13, 1, 5, 0, 15, 10, 3, 9, 8, 6),
     ROW ( 4, 2, 1, 11, 10, 13, 7, 8, 15, 9, 12, 5, 6, 3, 0, 14),
     ROW (11, 8, 12, 7, 1, 14, 2, 13, 6, 15, 0, 9, 10, 4, 5, 3))
end function

```

```

function S6 : S_BOX_ARRAY is
  return S_BOX_ARRAY
    (ROW (12, 1, 10, 15, 9, 2, 6, 8, 0, 13, 3, 4, 14, 7, 5, 11),
     ROW (10, 15, 4, 2, 7, 12, 9, 5, 6, 1, 13, 14, 0, 11, 3, 8),
     ROW ( 9, 14, 15, 5, 2, 8, 12, 3, 7, 0, 4, 10, 1, 13, 11, 6),
     ROW ( 4, 3, 2, 12, 9, 5, 15, 10, 11, 14, 1, 7, 6, 0, 8, 13))
end function

```

```

function S7 : S_BOX_ARRAY is
  return S_BOX_ARRAY
    (ROW ( 4, 11, 2, 14, 15, 0, 8, 13, 3, 12, 9, 7, 5, 10, 6, 1),
     ROW (13, 0, 11, 7, 4, 9, 1, 10, 14, 3, 5, 12, 2, 15, 8, 6),
     ROW ( 1, 4, 11, 13, 12, 3, 7, 14, 10, 15, 6, 8, 0, 5, 9, 2),
     ROW ( 6, 11, 13, 8, 1, 4, 10, 7, 9, 5, 0, 15, 14, 2, 3, 12))
end function

```

```
function S8 : S_BOX_ARRAY is  
  return S_BOX_ARRAY  
    (ROW (13, 2, 8, 4, 6, 15, 11, 1, 10, 9, 3, 14, 5, 0, 12, 7),  
     ROW ( 1, 15, 13, 8, 10, 3, 7, 4, 12, 5, 6, 11, 0, 14, 9, 2),  
     ROW ( 7, 11, 4, 1, 9, 12, 14, 2, 0, 6, 10, 13, 15, 3, 5, 8),  
     ROW ( 2, 1, 14, 7, 4, 10, 8, 13, 15, 12, 9, 0, 3, 5, 6, 11))  
end function  
  
end module
```

A.6 Module CHANNELS

```
module CHANNELS (TYPES) is
```

— channel types for bit vectors

```
channel C4 is  
  (BIT4)  
end channel
```

```
channel C6 is  
  (BIT6)  
end channel
```

```
channel C32 is  
  (BIT32)  
end channel
```

```
channel C48 is  
  (BIT48)  
end channel
```

```
channel C56 is  
  (BIT56)  
end channel
```

```
channel C64 is  
  (BIT64)  
end channel
```

— channel types for scalar data types

```
channel CB is  
  (BOOL)  
end channel
```

```
channel CIT is  
  (ITERATION)  
end channel
```

```

channel CP is
  (PHASE)
end channel

channel CS is
  (SHIFT)
end channel

end module

```

A.7 Module CONTROLLER

```

module CONTROLLER (CHANNELS) is

```

— *CONTROLLER* executes five concurrent processes controlling the various
 — multiplexers and the shift register, which are synchronized via a sixth
 — process counting the iterations

```

process CONTROLLER [CRYPT: CB,
                    CTRL_CL, CTRL_CR: CP,
                    CTRL_SHIFT: CS, CTRL_DK, CTRL_CK: CP] is
  hide CS: CIT in
    par CS in
      COUNTER [CS]
      ||
      CTRL_MUX_LR [CS, CTRL_CL]
      ||
      CTRL_MUX_LR [CS, CTRL_CR]
      ||
      CTRL_SHIFT [CRYPT, CS, CTRL_SHIFT]
      ||
      CTRL_DMUX_K [CS, CTRL_DK]
      ||
      CTRL_MUX_K [CS, CTRL_CK]
    end par
  end hide
end process

```

— *COUNTER* counts the iterations (modulo 17)

```

process COUNTER [CS: CIT] is
  var IT: ITERATION in
    IT := 0;
    loop
      CS (IT);
      IT := ITERATION (((NAT (IT) + 1) mod 17))
    end loop
  end var
end process

```

— *CTRL_MUX_LR* generates 1 F, then 15 Ns, and finally 1 L to control the multiplexers in the data path

```

process CTRL_MUX_LR [CS: CIT, CTRL: CP] is
  var IT: ITERATION in
    loop
      CS (?IT);
      if IT == (0 of ITERATION) then
        CTRL (F)
      elsif IT == last then
        CTRL (L)
      else
        CTRL (N)
      end if
    end loop
  end var
end process

```

— *CTRL_SHIFT* controls the shift register

```

process CTRL_SHIFT [CRYPT: CB, CS: CIT, CTRL: CS] is
  var CRYPT: BOOL, IT: ITERATION in
    loop
      CRYPT (?CRYPT);
      loop LL in
        CS (?IT);
        if IT == last then
          break LL
        elsif CRYPT then
          if (IT == (0 of ITERATION)) or (IT == (1 of ITERATION)) or
            (IT == (8 of ITERATION)) or (IT == (15 of ITERATION))
          then
            CTRL (LS1)
          else
            CTRL (LS2)
          end if
        else
          if IT == (0 of ITERATION) then
            CTRL (NO)
          elsif (IT == (1 of ITERATION)) or
            (IT == (8 of ITERATION)) or
            (IT == (15 of ITERATION))
          then
            CTRL (RS1)
          else
            CTRL (RS2)
          end if
        end if
      end loop
    end loop

```

```

    end loop
  end var
end process

```

— *CTRLDMUX_K generates 15 Ns and 1 L to control the doubling multiplexer*

```

process CTRLDMUX_K [CS: CIT, CTRL: CP] is
  var IT: ITERATION in
    loop
      CS (?IT);
      if IT == (15 of ITERATION) then
        CTRL (L)
      elsif IT != last then
        CTRL (N)
      end if
    end loop
  end var
end process

```

— *CTRLMUX_K generates 1 F and 15 Ns to control the key path multiplexer*

```

process CTRLMUX_K [CS: CIT, CTRL: CP] is
  var IT: ITERATION in
    loop
      CS (?IT);
      if IT == (0 of ITERATION) then
        CTRL (F)
      elsif IT != last then
        CTRL (N)
      end if
    end loop
  end var
end process

```

```

end module

```

A.8 Module KEY_PATH

```

module KEY_PATH (CHANNELS) is

```

— *KEY_PATH generates the 16 subkeys of the key schedule*

```

process KEY_PATH [KEY: C64, SUBKEY: C48,
                 CTRL_SHIFT: CS, CTRL_DK, CTRL_CK: CP] is
  hide FIRST_K, INTERMEDIATE_K: C56 in
    par
      FIRST_K ->
        PC1 [KEY, FIRST_K]
    ||

```



```

FIRST_K, INTERMEDIATE_K →
  hide K, KKK, SK: C56 in
    par
      K, SK →
        SHIFT_REGISTER [CTRL_SHIFT, K, SK]
    ||
      SK, KKK →
        DUPLICATE_K [CTRL_DK, SK, INTERMEDIATE_K, KKK]
    ||
      KKK, K →
        CHOOSE_K [CTRL_CK, FIRST_K, KKK, K]
    end par
  end hide
||
  INTERMEDIATE_K →
    PC2 [INTERMEDIATE_K, SUBKEY]
end par
end hide
end process

```

— *PC1 applies PC1 to select a 56-bit vector from the initial 64-bit key*

```

process PC1 [KEY: C64, FIRST_K: C56] is
  var K64: BIT64 in
    loop
      KEY (?K64);
      FIRST_K (PC1 (K64))
    end loop
  end var
end process

```

— *SHIFT_REGISTER performs, depending on the iteration, one or two shifts to the left or right of a 56-bit word*

```

process SHIFT_REGISTER [CTRL: CS, INPUT, OUTPUT: C56] is
  var CTRL: SHIFT, I56: BIT56 in
    loop
      par
        CTRL (?CTRL)
      ||
        INPUT (?I56)
      end par;
      case CTRL in
        NO →
          OUTPUT (I56)
        | LS1 →
          OUTPUT (LSHIFT (I56))
        | LS2 →
          OUTPUT (LSHIFT (LSHIFT (I56)))
        | RS1 →

```

```

        OUTPUT (RSHIFT (156))
    | RS2 ->
        OUTPUT (RSHIFT (RSHIFT (156)))
    end case
end loop
end var
end process

```

— *DUPLICATE_K* reads a 56-bit vector from *INPUT* and outputs it to *OUTPUT1*
— and *OUTPUT2*, but for the last iteration, where it outputs only to
— *OUTPUT1*. Because *DUPLICATE_K* always reads from *INPUT*, the order of the
— rendezvous on *CTRL* and *INPUT* is arbitrary.

```

process DUPLICATE_K [CTRL: CP, INPUT, OUTPUT1, OUTPUT2: C56] is
    var CTRL: PHASE, 156:BIT56 in
        loop
            par
                CTRL (?CTRL)
            ||
                INPUT (?156)
            end par;
            if CTRL = L then
                OUTPUT1 (156)
            else — assert (CTRL = N)
                par
                    OUTPUT1 (156)
                ||
                    OUTPUT2 (156)
                end par
            end if
        end loop
    end var
end process

```

— *CHOOSE_K* closes the loop in the key path, by redirecting the input on
— *INPUT* to *OUTPUT*, but for the first iteration where the original key is
— read on *FIRST_IN*

```

process CHOOSE_K [CTRL: CP, FIRST_IN, INPUT, OUTPUT: C56] is
    var CTRL: PHASE, 156:BIT56 in
        loop
            CTRL (?CTRL);
            if CTRL = F then
                FIRST_IN (?156)
            else — assert (CTRL = N)
                INPUT (?156)
            end if;
            OUTPUT (156)
        end loop
    end var

```

end process

— PC2 applies PC2 to generate the current subkey

```

process PC2 [KK: C56, SUBKEY: C48] is
  var I56: BIT56 in
    loop
      KK (?I56);
      SUBKEY (PC2 (I56))
    end loop
  end var
end process

```

end module

A.9 Module DATA_PATH

```

module DATA_PATH (PERMUTATION_FUNCTIONS, CIPHER) is

```

— DATA_PATH performs the 16 iterations ciphering DATA with the subkeys

— read on gate SUBKEY

```

process DATA_PATH [DATA, OUTPUT: C64, SUBKEY: C48, CTRL_CL, CTRL_CR: CP] is
  hide FIRST_L, FIRST_R, OUTPUT_L, OUTPUT_R: C32 in
    par
      FIRST_L, FIRST_R →
        IP [DATA, FIRST_L, FIRST_R]
    ||
      FIRST_L, FIRST_R, OUTPUT_L, OUTPUT_R →
        hide CL_XR, CR_FX, FX_XR, XR_CR, CR_CL: C32 in
          par
            CR_CL, CL_XR →
              CHOOSE_L [CTRL_CL, FIRST_L, CR_CL, CL_XR, OUTPUT_L]
            ||
            XR_CR, CR_CL, CR_FX →
              CHOOSE_R [CTRL_CR, FIRST_R, XR_CR, CR_CL, CR_FX,
                OUTPUT_R]
            ||
            CR_FX, FX_XR →
              CIPHER [SUBKEY, CR_FX, FX_XR]
            ||
            CL_XR, FX_XR, XR_CR →
              XOR_32 [CL_XR, FX_XR, XR_CR]
          end par
        end hide
    ||
      OUTPUT_L, OUTPUT_R →
        IIP [OUTPUT_L, OUTPUT_R, OUTPUT]
    end par
  end hide
end process

```

— *IP* applies the initial permutation *IP* to the initial 64-bit vector
 — received on gate *DATA* and breaks the resulting 64-bit vector into
 — two 32-bit vectors *L* and *R*

```

process IP [DATA: C64, FIRST_L, FIRST_R: C32] is
  var I64: BIT64 in
    loop
      DATA (?I64);
      I64 := IP (I64);
      par
        FIRST_L (1TO32 (I64))
        ||
        FIRST_R (33TO64 (I64))
      end par
    end loop
  end var
end process

```

— *CHOOSE_L* reads a 32-bit vector from *INPUT* and outputs to *OUTPUT*, but for
 — the first iteration, where it reads from *FIRST_IN*, and the last
 — iteration, where it outputs to *LAST_OUT*

```

process CHOOSE_L [CTRL: CP, FIRST_IN, INPUT, OUTPUT, LAST_OUT: C32] is
  var CTRL: PHASE, L32: BIT32 in
    loop
      CTRL (?CTRL);
      case CTRL in
        F ->
          FIRST_IN (?L32);
          OUTPUT (L32)
        | N ->
          INPUT (?L32);
          OUTPUT (L32)
        | L ->
          INPUT (?L32);
          LAST_OUT (L32)
      end case
    end loop
  end var
end process

```

— *CHOOSE_R* reads a 32-bit vector from *INPUT* and outputs to *OUT1* and *OUT2*,
 — but for the first iteration, where it reads from *FIRST_IN*, and the last
 — one, where it outputs to *LAST_OUT*

```

process CHOOSE_R [CTRL: CP, FIRST_IN, INPUT, OUT1, OUT2, LAST_OUT: C32] is
  var CTRL: PHASE, R32: BIT32 in
    loop

```

```

CTRL (?CTRL);
case CTRL in
  F →
    FIRST_IN (?R32);
    par
      OUT1 (R32)
    ||
      OUT2 (R32)
    end par
  | N →
    INPUT (?R32);
    par
      OUT1 (R32)
    ||
      OUT2 (R32)
    end par
  | L →
    INPUT (?R32);
    LAST_OUT (R32)
end case
end loop
end var
end process

```

— *XOR_32 asynchronously reads two 32-bit vectors and outputs their bitwise sum*

```

process XOR_32 [A, B, R: C32] is
  var A32, B32: BIT32 in
    loop
      par
        A (?A32)
      ||
        B (?B32)
      end par;
      R (XOR (A32, B32))
    end loop
  end var
end process

```

— *IIP assembles the two 32-bit vectors computed by the algorithm to a 64-bit vector and applies the inverse initial permutation IIP to compute the final result*

```

process IIP [OUTPUT_L, OUTPUT_R: C32, OUTPUT: C64] is
  var OL, OH: BIT32 in
    loop
      par
        OUTPUT_L (?OL)
      ||

```

```

        OUTPUT_R (?OH)
      end par;
      OUTPUT (IIP (MK_64 (OH, OL)))
    end loop
  end var
end process

end module

```

A.10 Module CIPHER

```

module CIPHER (CHANNELS, S_BOX_FUNCTIONS) is

```

— *processes implementing the cipher function according to Fig. 2 of [DES]*

— *CIPHER computes "F (R, K) = P (Si (E (R) + K))"*

```

process CIPHER [K: C48, R, PX: C32] is
  hide ER: C48,
        IS1, IS2, IS3, IS4, IS5, IS6, IS7, IS8: C6,
        SO1, SO2, SO3, SO4, SO5, SO6, SO7, SO8: C4
  in
    par
      ER →
        E [R, ER]
    ||
      ER, IS1, IS2, IS3, IS4, IS5, IS6, IS7, IS8 →
        XOR_48 [ER, K, IS1, IS2, IS3, IS4, IS5, IS6, IS7, IS8]
    ||
      IS1, IS2, IS3, IS4, IS5, IS6, IS7, IS8,
      SO1, SO2, SO3, SO4, SO5, SO6, SO7, SO8 →
        par
          S1 [IS1, SO1]
        ||
          S2 [IS2, SO2]
        ||
          S3 [IS3, SO3]
        ||
          S4 [IS4, SO4]
        ||
          S5 [IS5, SO5]
        ||
          S6 [IS6, SO6]
        ||
          S7 [IS7, SO7]
        ||
          S8 [IS8, SO8]
        end par
    ||
      SO1, SO2, SO3, SO4, SO5, SO6, SO7, SO8 →
        P [SO1, SO2, SO3, SO4, SO5, SO6, SO7, SO8, PX]
    end par
end process

```

```

    end par
  end hide
end process

```

— *E expands a 32-bit word to a 48-bit word using function E*

```

process E [INPUT: C32, OUTPUT: C48] is
  var I32: BIT32 in
    loop
      INPUT (?I32);
      OUTPUT (E(I32))
    end loop
  end var
end process

```

— *XOR_48 asynchronously reads two 48-bit vectors and output their bitwise sum, splitted into eight 6-bit vectors*

```

process XOR_48 [A, B: C48, R1, R2, R3, R4, R5, R6, R7, R8: C6] is
  var A48, B48, I48: BIT48 in
    loop
      par
        A (?A48)
      ||
        B (?B48)
      end par;
      I48 := XOR (A48, B48);
      par
        R1 (1TO6 (I48))
      ||
        R2 (7TO12 (I48))
      ||
        R3 (13TO18 (I48))
      ||
        R4 (19TO24 (I48))
      ||
        R5 (25TO30 (I48))
      ||
        R6 (31TO36 (I48))
      ||
        R7 (37TO42 (I48))
      ||
        R8 (43TO48 (I48))
      end par
    end loop
  end var
end process

```

```
process S1 [INPUT: C6, OUTPUT: C4] is
  var l6: BIT6 in
    loop
      INPUT (?l6);
      OUTPUT (NAT_TO_BIT4 (S1[GET_ROW (l6)][GET_COLUMN (l6)]))
    end loop
  end var
end process
```

```
process S2 [INPUT: C6, OUTPUT: C4] is
  var l6: BIT6 in
    loop
      INPUT (?l6);
      OUTPUT (NAT_TO_BIT4 (S2[GET_ROW (l6)][GET_COLUMN (l6)]))
    end loop
  end var
end process
```

```
process S3 [INPUT: C6, OUTPUT: C4] is
  var l6: BIT6 in
    loop
      INPUT (?l6);
      OUTPUT (NAT_TO_BIT4 (S3[GET_ROW (l6)][GET_COLUMN (l6)]))
    end loop
  end var
end process
```

```
process S4 [INPUT: C6, OUTPUT: C4] is
  var l6: BIT6 in
    loop
      INPUT (?l6);
      OUTPUT (NAT_TO_BIT4 (S4[GET_ROW (l6)][GET_COLUMN (l6)]))
    end loop
  end var
end process
```

```
process S5 [INPUT: C6, OUTPUT: C4] is
  var l6: BIT6 in
    loop
      INPUT (?l6);
      OUTPUT (NAT_TO_BIT4 (S5[GET_ROW (l6)][GET_COLUMN (l6)]))
    end loop
  end var
end process
```

```

process S6 [INPUT: C6, OUTPUT: C4] is
  var I6: BIT6 in
    loop
      INPUT (?I6);
      OUTPUT (NAT_TO_BIT4 (S6[GET_ROW (I6)][GET_COLUMN (I6)]))
    end loop
  end var
end process

```

```

process S7 [INPUT: C6, OUTPUT: C4] is
  var I6: BIT6 in
    loop
      INPUT (?I6);
      OUTPUT (NAT_TO_BIT4 (S7[GET_ROW (I6)][GET_COLUMN (I6)]))
    end loop
  end var
end process

```

```

process S8 [INPUT: C6, OUTPUT: C4] is
  var I6: BIT6 in
    loop
      INPUT (?I6);
      OUTPUT (NAT_TO_BIT4 (S8[GET_ROW (I6)][GET_COLUMN (I6)]))
    end loop
  end var
end process

```

— *P* collects the results of the eight processes *S_BOX_i* (on *IN_i*) and
 — outputs them in a single transition exit; the permutation *P* is applied
 — in a second step when outputting the result on *OUTPUT*.

```

process P [IN1, IN2, IN3, IN4, IN5, IN6, IN7, IN8: C4, OUTPUT: C32] is
  var I1, I2, I3, I4, I5, I6, I7, I8: BIT4 in
    loop
      par
        IN1 (?I1)
        ||
        IN2 (?I2)
        ||
        IN3 (?I3)
        ||
        IN4 (?I4)
        ||
        IN5 (?I5)
      end par
    end loop

```

```

    ||
    ||   IN6 (?I6)
    ||
    ||   IN7 (?I7)
    ||
    ||   IN8 (?I8)
    ||   end par;
    ||   OUTPUT (P (MK_32 (I1 , I2 , I3 , I4 , I5 , I6 , I7 , I8 )))
  end loop
end var
end process

end module

```

A.11 Module DES

The module DES.Int defines the architecture of the asynchronous DES together with the principal process MAIN instantiating process DES.

```

module DES (CONTROLLER, DATA_PATH, KEY_PATH) is

  process DES [CRYPT: CB, KEY, DATA, OUTPUT: C64] is
    hide SUBKEY: C48,
          CTRL_CL, CTRL_CR: CP,
          CTRL_SHIFT: CS, CTRL_DK, CTRL_CK: CP
    in
      par
        SUBKEY, CTRL_CL, CTRL_CR →
          DATA_PATH [DATA, OUTPUT, SUBKEY, CTRL_CL, CTRL_CR]
      ||
        SUBKEY, CTRL_CK, CTRL_SHIFT, CTRL_DK →
          KEY_PATH [KEY, SUBKEY, CTRL_SHIFT, CTRL_DK, CTRL_CK]
      ||
        CTRL_CL, CTRL_CR, CTRL_CK, CTRL_SHIFT, CTRL_DK →
          CONTROLLER [CRYPT, CTRL_CL, CTRL_CR, CTRL_SHIFT, CTRL_DK,
                     CTRL_CK]
      end par
    end hide
  end process

```

```

process MAIN [CRYPT: CB, KEY, DATA, OUTPUT: C64] is
  DES [CRYPT, KEY, DATA, OUTPUT]
end process

end module

```

A.12 Model with Concrete Bits and Environment: DES_SAMPLE

This model instantiates the DES in a sequential environment providing input data and checking the output. Hence, this model can be used to directly (i.e., non compositionally) generate an LTS for the

concrete (and thus also the abstract) model. After hiding all offers and minimization for branching bisimulation, the generated LTS is the one shown in Figure 2.

```
module DES_SAMPLE (DES) is
```

```
— DES_SAMPLE uses concrete bits
```

```
process MAIN_SAMPLE [CRYPT: CB, KEY, DATA, OUTPUT: C64] is
  par CRYPT, KEY, DATA, OUTPUT in
    DES [CRYPT, KEY, DATA, OUTPUT]
  ||
    ENVIRONMENT [CRYPT, KEY, DATA, OUTPUT]
  end par
end process
```

```
— 64-bit constant frequently used as example for a key
```

```
function c_13345779_9BBCDFF1 : BIT64 is
  return MK_64 (0, 0, 0, 1, 0, 0, 1, 1, 0, 0, 1, 1, 0, 1, 0, 0,
                0, 1, 0, 1, 0, 1, 1, 1, 0, 1, 1, 1, 1, 0, 0, 1,
                1, 0, 0, 1, 1, 0, 1, 1, 1, 0, 1, 1, 1, 1, 0, 0,
                1, 1, 0, 1, 1, 1, 1, 1, 1, 1, 1, 1, 0, 0, 0, 1)
end function
```

```
— 64-bit constant frequently used as example data
```

```
function C_01234567_89ABCDEF : BIT64 is
  return MK_64 (0, 0, 0, 0, 0, 0, 0, 1, 0, 0, 1, 0, 0, 0, 1, 1,
                0, 1, 0, 0, 0, 1, 0, 1, 0, 1, 1, 0, 0, 1, 1, 1,
                1, 0, 0, 0, 1, 0, 0, 1, 1, 0, 1, 0, 1, 0, 1, 1,
                1, 1, 0, 0, 1, 1, 0, 1, 1, 1, 1, 0, 1, 1, 1, 1)
end function
```

```
— result of ciphering C_01234567_89ABCDEF with C_13345779_9BBCDFF1
```

```
function C_85E81354_0F0AB405 : BIT64 is
  return MK_64 (1, 0, 0, 0, 0, 1, 0, 1, 1, 1, 1, 0, 1, 0, 0, 0,
                0, 0, 0, 1, 0, 0, 1, 1, 0, 1, 0, 1, 0, 1, 0, 0,
                0, 0, 0, 0, 1, 1, 1, 1, 0, 0, 0, 0, 1, 0, 1, 0,
                1, 0, 1, 1, 0, 1, 0, 0, 0, 0, 0, 0, 0, 1, 0, 1)
end function
```

```
— process simulating the environment in order to close the system,  

— executing a single encryption of c_01234567_89abcdef with  

— c_13345779_9BBCDFF1
```

```
process ENVIRONMENT [CRYPT: CB, KEY, DATA, OUTPUT: C64] is
  CRYPT (true);
```

```

KEY (c_13345779_9BBCDFF1);
DATA (c_01234567_89abcdef);
— cipher of c_01234567_89abcdef with c_13345779_9BBCDFF1
OUTPUT (c_85e81354_0f0ab405);
stop
end process

end module

```

A.13 Module PROPERTY_4

```

module property_4 is

```

```

— synchronization channel without any offer

```

```

channel none is
  ()
end channel

```

```

— process describing a loop starting with a synchronization on gate CRYPT,
— followed by 16 synchronizations on gate SUBKEY, where the synchronization
— on CRYPT corresponding to the next iteration can already appear after
— 14 synchronizations on SUBKEY.
— this process is used to verify the presence of 16 iterations in the DES.

```

```

process MAIN [CRYPT, SUBKEY: none] is
  CRYPT;
  loop
    var IT: NAT in
      for IT := 0 while IT < 14 by IT := IT + 1 loop
        SUBKEY
      end loop
    end var;
    par
      SUBKEY; SUBKEY
    ||
      CRYPT
    end par
  end loop
end process

end module

```

B LOTOS Specification of an Asynchronous DES

This appendix gives the complete LOTOS models of the DES, as required by the SVL verification scenario given in Appendix D. For an introduction to LOTOS, its syntax and semantics, see the international

standard [12] or one of the tutorials listed on the CADP website¹². In the sequel, a LOTOS model is called a “specification”, in conformance with the terminology of the LOTOS standard.

B.1 Library BIT_CONCRETE

The definition of type `BIT` by library `BIT_CONCRETE` is not strictly necessary, because one could use the library `BIT` provided with the CADP toolbox, which defines many more operations than just `xor`. Thus, the library `BIT_CONCRETE` is included here for better comparison with its abstract version (see Appendix B.2 below).

```

type BIT is BOOLEAN
  sorts BIT
  opns 0 (*! implementedby BIT_ZERO constructor *) : -> BIT
       1 (*! implementedby BIT_ONE constructor *) : -> BIT
endtype

```

B.2 Library BIT_ABSTRACT

This library is a replacement of the type `BIT`, transforming the two-valued type into a singleton, which transitively transforms all bit vectors into singletons as well, thus completely abstracting data.

```

type BIT is BOOLEAN
  sorts BIT
  opns 0 (*! constructor *) : -> BIT
       1 : -> BIT
  eqns
    ofsort BIT
      1 = 0;
endtype

```

B.3 Library TYPES

This library defines several data types modeling different sizes of bit vectors and types required for the control of the DES.

```

(* ----- *)
(* exclusive-or operation on (abstract or concrete) bits *)

type EXTENDED_BIT is BIT
  opns _xor_ : BIT, BIT -> BIT
  eqns
    forall B1, B2 : BIT
      ofsort BIT
        B1 xor B1 = 0;
        B1 xor B2 = 1; (* assuming decreasing priority among equations *)
endtype

(* ----- *)

```

¹²<http://cadp.inria.fr/tutorial/#lotos>

(* data types for counting the iterations of the algorithm *)

```
type ITERATION_AS_RENAMED_NAT is NATURAL renamedby
  sortnames ITERATION for NAT
endtype
```

```
type ITERATION is BOOLEAN, ITERATION_AS_RENAMED_NAT
  opns 15 : → ITERATION
       16 : → ITERATION
       17 : → ITERATION
       NEXT : ITERATION → ITERATION
       LAST : ITERATION → BOOLEAN
  eqns
    forall IT : ITERATION
      ofsort ITERATION
        15 = Succ (Succ (Succ (Succ (Succ (Succ (9))))));
        16 = Succ (15);
        17 = Succ (16);
      ofsort ITERATION
        NEXT (IT) = (IT + 1) mod 17;
      ofsort BOOLEAN
        LAST (IT) = IT == 16;
  endtype
```

(* _____ *)
 (* data type for the control signals used for the multiplexers *)

```
type PHASE is BOOLEAN, ITERATION
  sorts PHASE
  opns F (! constructor *) : → PHASE (* first iteration *)
       N (! constructor *) : → PHASE (* intermediate iteration *)
       L (! constructor *) : → PHASE (* last iteration *)
       ==_ : PHASE, PHASE → BOOLEAN
       MUX_DATA : ITERATION → PHASE
       MUX_K : ITERATION → PHASE
       DMUX_K : ITERATION → PHASE
  eqns
    forall IT : ITERATION,
      P, P1, P2 : PHASE
      ofsort BOOLEAN
        F == F = true;
        N == N = true;
        L == L = true;
        P1 == P2 = false;
      ofsort PHASE
        MUX_DATA (0) = F;
        (IT == 16) ⇒ MUX_DATA (IT) = L;
        MUX_DATA (IT) = N;
      ofsort PHASE
        MUX_K (0) = F;
        MUX_K (IT) = N;
      ofsort PHASE
```

```
(IT == 15) => DMUX_K (IT) = L;
DMUX_K (IT) = N;
```

```
endtype
```

```
(* ----- *)
(* data type for the controlling the behavior of the shift register *)
```

```
type SHIFT is BOOLEAN, ITERATION
```

```
  sorts SHIFT
```

```
  opns NO  (*! constructor *) : -> SHIFT (* no shift *)
        LS1 (*! constructor *) : -> SHIFT (* 1 left shift *)
        LS2 (*! constructor *) : -> SHIFT (* 2 left shifts *)
        RS1 (*! constructor *) : -> SHIFT (* 1 right shift *)
        RS2 (*! constructor *) : -> SHIFT (* 2 right shifts *)
        ==_ : SHIFT, SHIFT -> BOOL
        SHIFT_CODE : ITERATION, BOOL -> SHIFT
```

```
  eqns
```

```
    forall IT : ITERATION,
           S, S1, S2 : SHIFT
```

```
    ofsort BOOL
```

```
      NO == NO = true;
      LS1 == LS1 = true;
      LS2 == LS2 = true;
      RS1 == RS1 = true;
      RS2 == RS2 = true;
      S1 == S2 = false;
```

```
    ofsort SHIFT
```

```
      (IT == 0) => SHIFT_CODE (IT, false) = NO;
      (IT == 1) => SHIFT_CODE (IT, false) = RS1;
      (IT == 8) => SHIFT_CODE (IT, false) = RS1;
      (IT == 15) => SHIFT_CODE (IT, false) = RS1;
      SHIFT_CODE (IT, false) = RS2;
      (IT == 0) => SHIFT_CODE (IT, true) = LS1;
      (IT == 1) => SHIFT_CODE (IT, true) = LS1;
      (IT == 8) => SHIFT_CODE (IT, true) = LS1;
      (IT == 15) => SHIFT_CODE (IT, true) = LS1;
      SHIFT_CODE (IT, true) = LS2;
```

```
endtype
```

```
(* ----- *)
(* data type for 4-bit vectors *)
```

```
type BIT4 is EXTENDED_BIT
```

```
  sorts BIT4 (*! implementedby ADT_BIT4 *)
```

```
  opns
```

```
    MK_4 (*! implementedby MK_4 constructor *) :
          BIT, BIT, BIT, BIT -> BIT4
```

```
endtype
```

```
(* ----- *)
(* data type for 6-bit vectors *)
```

```

type BIT6 is EXTENDED_BIT
  sorts BIT6
  opns
    MK_6 (constructor *) : BIT, BIT, BIT, BIT, BIT, BIT → BIT6
endtype

(----- *)
(data type for 32-bit vectors *)

type BIT32 is EXTENDED_BIT, BIT4
  sorts BIT32
  opns
    MK_32 (constructor *) : BIT, BIT, BIT, BIT, BIT, BIT, BIT, BIT,
      BIT, BIT, BIT, BIT, BIT, BIT, BIT, BIT,
      BIT, BIT, BIT, BIT, BIT, BIT, BIT, BIT,
      BIT, BIT, BIT, BIT, BIT, BIT, BIT, BIT
      → BIT32

    (bitwise xor *)
    XOR : BIT32, BIT32 → BIT32
    (concatenation of eight 4-bit vectors to form a 32-bit vector *)
    MK_32 : BIT4, BIT4, BIT4, BIT4, BIT4, BIT4, BIT4, BIT4 → BIT32
eqns
  forall A1, A2, A3, A4, A5, A6, A7, A8,
    A9, A10, A11, A12, A13, A14, A15, A16,
    A17, A18, A19, A20, A21, A22, A23, A24,
    A25, A26, A27, A28, A29, A30, A31, A32,
    B1, B2, B3, B4, B5, B6, B7, B8,
    B9, B10, B11, B12, B13, B14, B15, B16,
    B17, B18, B19, B20, B21, B22, B23, B24,
    B25, B26, B27, B28, B29, B30, B31, B32: BIT
  ofsort BIT32
    XOR (MK_32 (A1, A2, A3, A4, A5, A6, A7, A8,
      A9, A10, A11, A12, A13, A14, A15, A16,
      A17, A18, A19, A20, A21, A22, A23, A24,
      A25, A26, A27, A28, A29, A30, A31, A32),
      MK_32 (B1, B2, B3, B4, B5, B6, B7, B8,
      B9, B10, B11, B12, B13, B14, B15, B16,
      B17, B18, B19, B20, B21, B22, B23, B24,
      B25, B26, B27, B28, B29, B30, B31, B32)) =
    MK_32 (A1 xor B1, A2 xor B2, A3 xor B3, A4 xor B4,
      A5 xor B5, A6 xor B6, A7 xor B7, A8 xor B8,
      A9 xor B9, A10 xor B10, A11 xor B11, A12 xor B12,
      A13 xor B13, A14 xor B14, A15 xor B15, A16 xor B16,
      A17 xor B17, A18 xor B18, A19 xor B19, A20 xor B20,
      A21 xor B21, A22 xor B22, A23 xor B23, A24 xor B24,
      A25 xor B25, A26 xor B26, A27 xor B27, A28 xor B28,
      A29 xor B29, A30 xor B30, A31 xor B31, A32 xor B32);
  ofsort BIT32
    MK_32 (MK_4 (B1, B2, B3, B4), MK_4 (B5, B6, B7, B8),
      MK_4 (B9, B10, B11, B12), MK_4 (B13, B14, B15, B16),
      MK_4 (B17, B18, B19, B20), MK_4 (B21, B22, B23, B24),
      MK_4 (B25, B26, B27, B28), MK_4 (B29, B30, B31, B32)) =

```



```

MK_32 (B1, B2, B3, B4, B5, B6, B7, B8,
      B9, B10, B11, B12, B13, B14, B15, B16,
      B17, B18, B19, B20, B21, B22, B23, B24,
      B25, B26, B27, B28, B29, B30, B31, B32);

```

endtype

```

(* ----- *)
(* data type for 48-bit vectors *)

```

type BIT48 **is** EXTENDED_BIT, BIT6

sorts BIT48

opns

```

MK_48 (*! constructor *) : BIT, BIT, BIT, BIT, BIT, BIT, BIT, BIT,
                                     BIT, BIT, BIT, BIT, BIT, BIT, BIT, BIT,
                                     BIT, BIT, BIT, BIT, BIT, BIT, BIT, BIT,
                                     BIT, BIT, BIT, BIT, BIT, BIT, BIT, BIT,
                                     BIT, BIT, BIT, BIT, BIT, BIT, BIT, BIT,
                                     BIT, BIT, BIT, BIT, BIT, BIT, BIT, BIT
      -> BIT48

```

(* bitwise xor *)

XOR : BIT48, BIT48 -> BIT48

(* eight projection functions from 48-bit vectors to 6-bit vectors *)

```

1TO6 : BIT48 -> BIT6
7TO12 : BIT48 -> BIT6
13TO18 : BIT48 -> BIT6
19TO24 : BIT48 -> BIT6
25TO30 : BIT48 -> BIT6
31TO36 : BIT48 -> BIT6
37TO42 : BIT48 -> BIT6
43TO48 : BIT48 -> BIT6

```

eqns

```

forall A1, A2, A3, A4, A5, A6, A7, A8,
        A9, A10, A11, A12, A13, A14, A15, A16,
        A17, A18, A19, A20, A21, A22, A23, A24,
        A25, A26, A27, A28, A29, A30, A31, A32,
        A33, A34, A35, A36, A37, A38, A39, A40,
        A41, A42, A43, A44, A45, A46, A47, A48,
        B1, B2, B3, B4, B5, B6, B7, B8,
        B9, B10, B11, B12, B13, B14, B15, B16,
        B17, B18, B19, B20, B21, B22, B23, B24,
        B25, B26, B27, B28, B29, B30, B31, B32,
        B33, B34, B35, B36, B37, B38, B39, B40,
        B41, B42, B43, B44, B45, B46, B47, B48: BIT

```

ofsort BIT48

```

XOR (MK_48 (A1, A2, A3, A4, A5, A6, A7, A8,
             A9, A10, A11, A12, A13, A14, A15, A16,
             A17, A18, A19, A20, A21, A22, A23, A24,
             A25, A26, A27, A28, A29, A30, A31, A32,
             A33, A34, A35, A36, A37, A38, A39, A40,
             A41, A42, A43, A44, A45, A46, A47, A48),
      MK_48 (B1, B2, B3, B4, B5, B6, B7, B8,
            B9, B10, B11, B12, B13, B14, B15, B16,

```

```

        B17, B18, B19, B20, B21, B22, B23, B24,
        B25, B26, B27, B28, B29, B30, B31, B32,
        B33, B34, B35, B36, B37, B38, B39, B40,
        B41, B42, B43, B44, B45, B46, B47, B48)) =
MK_48 (A1 xor B1, A2 xor B2, A3 xor B3, A4 xor B4,
      A5 xor B5, A6 xor B6, A7 xor B7, A8 xor B8,
      A9 xor B9, A10 xor B10, A11 xor B11, A12 xor B12,
      A13 xor B13, A14 xor B14, A15 xor B15, A16 xor B16,
      A17 xor B17, A18 xor B18, A19 xor B19, A20 xor B20,
      A21 xor B21, A22 xor B22, A23 xor B23, A24 xor B24,
      A25 xor B25, A26 xor B26, A27 xor B27, A28 xor B28,
      A29 xor B29, A30 xor B30, A31 xor B31, A32 xor B32,
      A33 xor B33, A34 xor B34, A35 xor B35, A36 xor B36,
      A37 xor B37, A38 xor B38, A39 xor B39, A40 xor B40,
      A41 xor B41, A42 xor B42, A43 xor B43, A44 xor B44,
      A45 xor B45, A46 xor B46, A47 xor B47, A48 xor B48);
ofsort BIT6
1TO6 (MK_48 (B1, B2, B3, B4, B5, B6, B7, B8,
            B9, B10, B11, B12, B13, B14, B15, B16,
            B17, B18, B19, B20, B21, B22, B23, B24,
            B25, B26, B27, B28, B29, B30, B31, B32,
            B33, B34, B35, B36, B37, B38, B39, B40,
            B41, B42, B43, B44, B45, B46, B47, B48)) =
      MK_6 (B1, B2, B3, B4, B5, B6));
ofsort BIT6
7TO12 (MK_48 (B1, B2, B3, B4, B5, B6, B7, B8,
            B9, B10, B11, B12, B13, B14, B15, B16,
            B17, B18, B19, B20, B21, B22, B23, B24,
            B25, B26, B27, B28, B29, B30, B31, B32,
            B33, B34, B35, B36, B37, B38, B39, B40,
            B41, B42, B43, B44, B45, B46, B47, B48)) =
      MK_6 (B7, B8, B9, B10, B11, B12));
ofsort BIT6
13TO18 (MK_48 (B1, B2, B3, B4, B5, B6, B7, B8,
            B9, B10, B11, B12, B13, B14, B15, B16,
            B17, B18, B19, B20, B21, B22, B23, B24,
            B25, B26, B27, B28, B29, B30, B31, B32,
            B33, B34, B35, B36, B37, B38, B39, B40,
            B41, B42, B43, B44, B45, B46, B47, B48)) =
      MK_6 (B13, B14, B15, B16, B17, B18));
ofsort BIT6
19TO24 (MK_48 (B1, B2, B3, B4, B5, B6, B7, B8,
            B9, B10, B11, B12, B13, B14, B15, B16,
            B17, B18, B19, B20, B21, B22, B23, B24,
            B25, B26, B27, B28, B29, B30, B31, B32,
            B33, B34, B35, B36, B37, B38, B39, B40,
            B41, B42, B43, B44, B45, B46, B47, B48)) =
      MK_6 (B19, B20, B21, B22, B23, B24));
ofsort BIT6
25TO30 (MK_48 (B1, B2, B3, B4, B5, B6, B7, B8,
            B9, B10, B11, B12, B13, B14, B15, B16,
            B17, B18, B19, B20, B21, B22, B23, B24,

```

```

        B25, B26, B27, B28, B29, B30, B31, B32,
        B33, B34, B35, B36, B37, B38, B39, B40,
        B41, B42, B43, B44, B45, B46, B47, B48)) =
    MK_6 (B25, B26, B27, B28, B29, B30);
ofsort BIT6
    31TO36 (MK_48 (B1, B2, B3, B4, B5, B6, B7, B8,
        B9, B10, B11, B12, B13, B14, B15, B16,
        B17, B18, B19, B20, B21, B22, B23, B24,
        B25, B26, B27, B28, B29, B30, B31, B32,
        B33, B34, B35, B36, B37, B38, B39, B40,
        B41, B42, B43, B44, B45, B46, B47, B48)) =
    MK_6 (B31, B32, B33, B34, B35, B36);
ofsort BIT6
    37TO42 (MK_48 (B1, B2, B3, B4, B5, B6, B7, B8,
        B9, B10, B11, B12, B13, B14, B15, B16,
        B17, B18, B19, B20, B21, B22, B23, B24,
        B25, B26, B27, B28, B29, B30, B31, B32,
        B33, B34, B35, B36, B37, B38, B39, B40,
        B41, B42, B43, B44, B45, B46, B47, B48)) =
    MK_6 (B37, B38, B39, B40, B41, B42);
ofsort BIT6
    43TO48 (MK_48 (B1, B2, B3, B4, B5, B6, B7, B8,
        B9, B10, B11, B12, B13, B14, B15, B16,
        B17, B18, B19, B20, B21, B22, B23, B24,
        B25, B26, B27, B28, B29, B30, B31, B32,
        B33, B34, B35, B36, B37, B38, B39, B40,
        B41, B42, B43, B44, B45, B46, B47, B48)) =
    MK_6 (B43, B44, B45, B46, B47, B48);
endtype

(* ----- *)
(* data type for 56-bit vectors *)

type BIT56 is EXTENDED_BIT
sorts BIT56
opns
    MK_56 (*! constructor *) : BIT, BIT, BIT, BIT, BIT, BIT, BIT, BIT,
        BIT, BIT, BIT, BIT, BIT, BIT, BIT, BIT,
        BIT, BIT, BIT, BIT, BIT, BIT, BIT, BIT,
        BIT, BIT, BIT, BIT, BIT, BIT, BIT, BIT,
        BIT, BIT, BIT, BIT, BIT, BIT, BIT, BIT,
        BIT, BIT, BIT, BIT, BIT, BIT, BIT, BIT,
        BIT, BIT, BIT, BIT, BIT, BIT, BIT, BIT
        → BIT56
    (* left and right shift functions *)
    LSHIFT : BIT56 → BIT56
    RSHIFT : BIT56 → BIT56
eqns
forall B1, B2, B3, B4, B5, B6, B7, B8,
        B9, B10, B11, B12, B13, B14, B15, B16,
        B17, B18, B19, B20, B21, B22, B23, B24,
        B25, B26, B27, B28, B29, B30, B31, B32,

```

(concatenation of sixteen 4-bit vectors to form a 64-bit vector *)*

MK_64 *(*! implemented by CONCAT_BIT4 *)* :

BIT4, BIT4, BIT4, BIT4, BIT4, BIT4, BIT4, BIT4,
BIT4, BIT4, BIT4, BIT4, BIT4, BIT4, BIT4, BIT4 → BIT64

(concatenation of two 32-bit vectors to a 64-bit vector *)*

MK_64 : BIT32, BIT32 → BIT64

(two projection functions from 64-bit vectors to 32-bit vectors *)*

1TO32 : BIT64 → BIT32

33TO64 : BIT64 → BIT32

eqns

forall B1, B2, B3, B4, B5, B6, B7, B8,
B9, B10, B11, B12, B13, B14, B15, B16,
B17, B18, B19, B20, B21, B22, B23, B24,
B25, B26, B27, B28, B29, B30, B31, B32,
B33, B34, B35, B36, B37, B38, B39, B40,
B41, B42, B43, B44, B45, B46, B47, B48,
B49, B50, B51, B52, B53, B54, B55, B56,
B57, B58, B59, B60, B61, B62, B63, B64: **BIT**

ofsort BIT64

MK_64 (MK_4 (B1, B2, B3, B4), MK_4 (B5, B6, B7, B8),
MK_4 (B9, B10, B11, B12), MK_4 (B13, B14, B15, B16),
MK_4 (B17, B18, B19, B20), MK_4 (B21, B22, B23, B24),
MK_4 (B25, B26, B27, B28), MK_4 (B29, B30, B31, B32),
MK_4 (B33, B34, B35, B36), MK_4 (B37, B38, B39, B40),
MK_4 (B41, B42, B43, B44), MK_4 (B45, B46, B47, B48),
MK_4 (B49, B50, B51, B52), MK_4 (B53, B54, B55, B56),
MK_4 (B57, B58, B59, B60), MK_4 (B61, B62, B63, B64)) =

MK_64 (B1, B2, B3, B4, B5, B6, B7, B8,
B9, B10, B11, B12, B13, B14, B15, B16,
B17, B18, B19, B20, B21, B22, B23, B24,
B25, B26, B27, B28, B29, B30, B31, B32,
B33, B34, B35, B36, B37, B38, B39, B40,
B41, B42, B43, B44, B45, B46, B47, B48,
B49, B50, B51, B52, B53, B54, B55, B56,
B57, B58, B59, B60, B61, B62, B63, B64);

ofsort BIT64

MK_64 (MK_32 (B1, B2, B3, B4, B5, B6, B7, B8,
B9, B10, B11, B12, B13, B14, B15, B16,
B17, B18, B19, B20, B21, B22, B23, B24,
B25, B26, B27, B28, B29, B30, B31, B32),
MK_32 (B33, B34, B35, B36, B37, B38, B39, B40,
B41, B42, B43, B44, B45, B46, B47, B48,
B49, B50, B51, B52, B53, B54, B55, B56,
B57, B58, B59, B60, B61, B62, B63, B64)) =

MK_64 (B1, B2, B3, B4, B5, B6, B7, B8,
B9, B10, B11, B12, B13, B14, B15, B16,
B17, B18, B19, B20, B21, B22, B23, B24,
B25, B26, B27, B28, B29, B30, B31, B32,
B33, B34, B35, B36, B37, B38, B39, B40,
B41, B42, B43, B44, B45, B46, B47, B48,
B49, B50, B51, B52, B53, B54, B55, B56,
B57, B58, B59, B60, B61, B62, B63, B64);

```

ofsort BIT32
  1TO32 (MK_64 (B1, B2, B3, B4, B5, B6, B7, B8,
                B9, B10, B11, B12, B13, B14, B15, B16,
                B17, B18, B19, B20, B21, B22, B23, B24,
                B25, B26, B27, B28, B29, B30, B31, B32,
                B33, B34, B35, B36, B37, B38, B39, B40,
                B41, B42, B43, B44, B45, B46, B47, B48,
                B49, B50, B51, B52, B53, B54, B55, B56,
                B57, B58, B59, B60, B61, B62, B63, B64)) =
  MK_32 (B1, B2, B3, B4, B5, B6, B7, B8,
        B9, B10, B11, B12, B13, B14, B15, B16,
        B17, B18, B19, B20, B21, B22, B23, B24,
        B25, B26, B27, B28, B29, B30, B31, B32);
ofsort BIT32
  33TO64 (MK_64 (B1, B2, B3, B4, B5, B6, B7, B8,
                 B9, B10, B11, B12, B13, B14, B15, B16,
                 B17, B18, B19, B20, B21, B22, B23, B24,
                 B25, B26, B27, B28, B29, B30, B31, B32,
                 B33, B34, B35, B36, B37, B38, B39, B40,
                 B41, B42, B43, B44, B45, B46, B47, B48,
                 B49, B50, B51, B52, B53, B54, B55, B56,
                 B57, B58, B59, B60, B61, B62, B63, B64)) =
  MK_32 (B33, B34, B35, B36, B37, B38, B39, B40,
        B41, B42, B43, B44, B45, B46, B47, B48,
        B49, B50, B51, B52, B53, B54, B55, B56,
        B57, B58, B59, B60, B61, B62, B63, B64);

```

B.4 Library PERMUTATION_FUNCTIONS

This library defines the different permutation functions used by the DES.

```

type PERMUTATION_FUNCTIONS is BIT32, BIT48, BIT56, BIT64
opns E   : BIT32 → BIT48   (* expansion *)
      IP  : BIT64 → BIT64   (* initial permutation *)
      IIP : BIT64 → BIT64   (* inverse initial permutation *)
      P   : BIT32 → BIT32   (* permutation *)
      PC1 : BIT64 → BIT56   (* permuted choice 1 *)
      PC2 : BIT56 → BIT48   (* permuted choice 2 *)
eqns
forall B1, B2, B3, B4, B5, B6, B7, B8,
        B9, B10, B11, B12, B13, B14, B15, B16,
        B17, B18, B19, B20, B21, B22, B23, B24,
        B25, B26, B27, B28, B29, B30, B31, B32,
        B33, B34, B35, B36, B37, B38, B39, B40,
        B41, B42, B43, B44, B45, B46, B47, B48,
        B49, B50, B51, B52, B53, B54, B55, B56,
        B57, B58, B59, B60, B61, B62, B63, B64 : BIT
ofsort BIT48
  E (MK_32 (B1, B2, B3, B4, B5, B6, B7, B8,
           B9, B10, B11, B12, B13, B14, B15, B16,
           B17, B18, B19, B20, B21, B22, B23, B24,

```

```

    MK_48 (B25, B26, B27, B28, B29, B30, B31, B32)) =
    (B32, B1, B2, B3, B4, B5,
     B4, B5, B6, B7, B8, B9,
     B8, B9, B10, B11, B12, B13,
     B12, B13, B14, B15, B16, B17,
     B16, B17, B18, B19, B20, B21,
     B20, B21, B22, B23, B24, B25,
     B24, B25, B26, B27, B28, B29,
     B28, B29, B30, B31, B32, B1);

ofsort BIT32
  P (MK_32 (B1, B2, B3, B4, B5, B6, B7, B8,
            B9, B10, B11, B12, B13, B14, B15, B16,
            B17, B18, B19, B20, B21, B22, B23, B24,
            B25, B26, B27, B28, B29, B30, B31, B32)) =
    MK_32 (B16, B7, B20, B21,
            B29, B12, B28, B17,
            B1, B15, B23, B26,
            B5, B18, B31, B10,
            B2, B8, B24, B14,
            B32, B27, B3, B9,
            B19, B13, B30, B6,
            B22, B11, B4, B25);

ofsort BIT56
  PC1 (MK_64 (B1, B2, B3, B4, B5, B6, B7, B8,
              B9, B10, B11, B12, B13, B14, B15, B16,
              B17, B18, B19, B20, B21, B22, B23, B24,
              B25, B26, B27, B28, B29, B30, B31, B32,
              B33, B34, B35, B36, B37, B38, B39, B40,
              B41, B42, B43, B44, B45, B46, B47, B48,
              B49, B50, B51, B52, B53, B54, B55, B56,
              B57, B58, B59, B60, B61, B62, B63, B64)) =
    MK_56 (B57, B49, B41, B33, B25, B17, B9,
            B1, B58, B50, B42, B34, B26, B18,
            B10, B2, B59, B51, B43, B35, B27,
            B19, B11, B3, B60, B52, B44, B36,
            B63, B55, B47, B39, B31, B23, B15,
            B7, B62, B54, B46, B38, B30, B22,
            B14, B6, B61, B53, B45, B37, B29,
            B21, B13, B5, B28, B20, B12, B4);

ofsort BIT48
  PC2 (MK_56 (B1, B2, B3, B4, B5, B6, B7, B8,
              B9, B10, B11, B12, B13, B14, B15, B16,
              B17, B18, B19, B20, B21, B22, B23, B24,
              B25, B26, B27, B28, B29, B30, B31, B32,
              B33, B34, B35, B36, B37, B38, B39, B40,
              B41, B42, B43, B44, B45, B46, B47, B48,
              B49, B50, B51, B52, B53, B54, B55, B56)) =
    MK_48 (B14, B17, B11, B24, B1, B5,
            B3, B28, B15, B6, B21, B10,
            B23, B19, B12, B4, B26, B8,
            B16, B7, B27, B20, B13, B2,
            B41, B52, B31, B37, B47, B55,

```

```

        B30, B40, B51, B45, B33, B48,
        B44, B49, B39, B56, B34, B53,
        B46, B42, B50, B36, B29, B32);
ofsort BIT64
  IP (MK_64 (B1, B2, B3, B4, B5, B6, B7, B8,
            B9, B10, B11, B12, B13, B14, B15, B16,
            B17, B18, B19, B20, B21, B22, B23, B24,
            B25, B26, B27, B28, B29, B30, B31, B32,
            B33, B34, B35, B36, B37, B38, B39, B40,
            B41, B42, B43, B44, B45, B46, B47, B48,
            B49, B50, B51, B52, B53, B54, B55, B56,
            B57, B58, B59, B60, B61, B62, B63, B64)) =
  MK_64 (B58, B50, B42, B34, B26, B18, B10, B2,
        B60, B52, B44, B36, B28, B20, B12, B4,
        B62, B54, B46, B38, B30, B22, B14, B6,
        B64, B56, B48, B40, B32, B24, B16, B8,
        B57, B49, B41, B33, B25, B17, B9, B1,
        B59, B51, B43, B35, B27, B19, B11, B3,
        B61, B53, B45, B37, B29, B21, B13, B5,
        B63, B55, B47, B39, B31, B23, B15, B7);
ofsort BIT64
  IIP (MK_64 (B1, B2, B3, B4, B5, B6, B7, B8,
            B9, B10, B11, B12, B13, B14, B15, B16,
            B17, B18, B19, B20, B21, B22, B23, B24,
            B25, B26, B27, B28, B29, B30, B31, B32,
            B33, B34, B35, B36, B37, B38, B39, B40,
            B41, B42, B43, B44, B45, B46, B47, B48,
            B49, B50, B51, B52, B53, B54, B55, B56,
            B57, B58, B59, B60, B61, B62, B63, B64)) =
  MK_64 (B40, B8, B48, B16, B56, B24, B64, B32,
        B39, B7, B47, B15, B55, B23, B63, B31,
        B38, B6, B46, B14, B54, B22, B62, B30,
        B37, B5, B45, B13, B53, B21, B61, B29,
        B36, B4, B44, B12, B52, B20, B60, B28,
        B35, B3, B43, B11, B51, B19, B59, B27,
        B34, B2, B42, B10, B50, B18, B58, B26,
        B33, B1, B41, B9, B49, B17, B57, B25);
endtype

```

B.5 Library S_BOX_FUNCTIONS

Contrary to the LNT model, the LOTOS model defines each S-box as a functions, which completely expresses the *function* of the corresponding S-box, rather than the array defining the S-box. This avoids the definition of additional data types for the array, together with the accessor functions (which are generated automatically by the LNT2LOTOS translator). Precisely, each of the following S-box functions associates to any 6-bit vector the 4-bit value encoding of the corresponding entry in the associated S-box table (see Appendix A.5 for an encoding of these tables). The DES standard defines that for a 6-bit vector $b_1b_2b_3b_4b_5b_6$, corresponds the entry in the b_1b_6 -th row and the $b_2b_3b_4b_5$ -th column. The defining equations are ordered such that the right hand sides correspond to the usual reading order of the S-box tables of the standard (rows from top to bottom, and each row from left to right).

The definitions of these functions use premisses, because in the case type **BIT** implements the abstract singleton type, 1 is no constructor and thus not supported on the left hand side of an equation, e.g., the equation

$$S1 \text{ (MK}_6 \text{ (0, 0, 0, 0, 1, 0))} = \text{MK}_4 \text{ (0, 1, 0, 0);}$$

would be rejected by the LOTOS compiler.

```

type S_BOX_FUNCTIONS is BIT4, BIT6
  opns S1 : BIT6 → BIT4
        S2 : BIT6 → BIT4
        S3 : BIT6 → BIT4
        S4 : BIT6 → BIT4
        S5 : BIT6 → BIT4
        S6 : BIT6 → BIT4
        S7 : BIT6 → BIT4
        S8 : BIT6 → BIT4

  eqns
    (*
     * in the equations below, premisses are used rather than pattern
     * matching because '1' is a constructor for type BIT_CONCRETE
     * but not for type BIT_ABSTRACT
     *)
    forall BV6 : BIT6
    ofsort BIT4
      BV6 = MK_6 (0, 0, 0, 0, 0, 0) ⇒ S1 (BV6) = MK_4 (1, 1, 1, 0);
      BV6 = MK_6 (0, 0, 0, 0, 1, 0) ⇒ S1 (BV6) = MK_4 (0, 1, 0, 0);
      BV6 = MK_6 (0, 0, 0, 1, 0, 0) ⇒ S1 (BV6) = MK_4 (1, 1, 0, 1);
      BV6 = MK_6 (0, 0, 0, 1, 1, 0) ⇒ S1 (BV6) = MK_4 (0, 0, 0, 1);
      BV6 = MK_6 (0, 0, 1, 0, 0, 0) ⇒ S1 (BV6) = MK_4 (0, 0, 1, 0);
      BV6 = MK_6 (0, 0, 1, 0, 1, 0) ⇒ S1 (BV6) = MK_4 (1, 1, 1, 1);
      BV6 = MK_6 (0, 0, 1, 1, 0, 0) ⇒ S1 (BV6) = MK_4 (1, 0, 1, 1);
      BV6 = MK_6 (0, 0, 1, 1, 1, 0) ⇒ S1 (BV6) = MK_4 (1, 0, 0, 0);
      BV6 = MK_6 (0, 1, 0, 0, 0, 0) ⇒ S1 (BV6) = MK_4 (0, 0, 1, 1);
      BV6 = MK_6 (0, 1, 0, 0, 1, 0) ⇒ S1 (BV6) = MK_4 (1, 0, 1, 0);
      BV6 = MK_6 (0, 1, 0, 1, 0, 0) ⇒ S1 (BV6) = MK_4 (0, 1, 1, 0);
      BV6 = MK_6 (0, 1, 0, 1, 1, 0) ⇒ S1 (BV6) = MK_4 (1, 1, 0, 0);
      BV6 = MK_6 (0, 1, 1, 0, 0, 0) ⇒ S1 (BV6) = MK_4 (0, 1, 0, 1);
      BV6 = MK_6 (0, 1, 1, 0, 1, 0) ⇒ S1 (BV6) = MK_4 (1, 0, 0, 1);
      BV6 = MK_6 (0, 1, 1, 1, 0, 0) ⇒ S1 (BV6) = MK_4 (0, 0, 0, 0);
      BV6 = MK_6 (0, 1, 1, 1, 1, 0) ⇒ S1 (BV6) = MK_4 (0, 1, 1, 1);
      BV6 = MK_6 (0, 0, 0, 0, 0, 1) ⇒ S1 (BV6) = MK_4 (0, 0, 0, 0);
      BV6 = MK_6 (0, 0, 0, 0, 1, 1) ⇒ S1 (BV6) = MK_4 (1, 1, 1, 1);
      BV6 = MK_6 (0, 0, 0, 1, 0, 1) ⇒ S1 (BV6) = MK_4 (0, 1, 1, 1);
      BV6 = MK_6 (0, 0, 0, 1, 1, 1) ⇒ S1 (BV6) = MK_4 (0, 1, 0, 0);
      BV6 = MK_6 (0, 0, 1, 0, 0, 1) ⇒ S1 (BV6) = MK_4 (1, 1, 1, 0);
      BV6 = MK_6 (0, 0, 1, 0, 1, 1) ⇒ S1 (BV6) = MK_4 (0, 0, 1, 0);
      BV6 = MK_6 (0, 0, 1, 1, 0, 1) ⇒ S1 (BV6) = MK_4 (1, 1, 0, 1);
      BV6 = MK_6 (0, 0, 1, 1, 1, 1) ⇒ S1 (BV6) = MK_4 (0, 0, 0, 1);
      BV6 = MK_6 (0, 1, 0, 0, 0, 1) ⇒ S1 (BV6) = MK_4 (1, 0, 1, 0);
      BV6 = MK_6 (0, 1, 0, 0, 1, 1) ⇒ S1 (BV6) = MK_4 (0, 1, 1, 0);
      BV6 = MK_6 (0, 1, 0, 1, 0, 1) ⇒ S1 (BV6) = MK_4 (1, 1, 0, 0);

```

```

BV6 = MK_6 (0, 1, 0, 1, 1, 1) => S1 (BV6) = MK_4 (1, 0, 1, 1);
BV6 = MK_6 (0, 1, 1, 0, 0, 1) => S1 (BV6) = MK_4 (1, 0, 0, 1);
BV6 = MK_6 (0, 1, 1, 0, 1, 1) => S1 (BV6) = MK_4 (0, 1, 0, 1);
BV6 = MK_6 (0, 1, 1, 1, 0, 1) => S1 (BV6) = MK_4 (0, 0, 1, 1);
BV6 = MK_6 (0, 1, 1, 1, 1, 1) => S1 (BV6) = MK_4 (1, 0, 0, 0);
BV6 = MK_6 (1, 0, 0, 0, 0, 0) => S1 (BV6) = MK_4 (0, 1, 0, 0);
BV6 = MK_6 (1, 0, 0, 0, 1, 0) => S1 (BV6) = MK_4 (0, 0, 0, 1);
BV6 = MK_6 (1, 0, 0, 1, 0, 0) => S1 (BV6) = MK_4 (1, 1, 1, 0);
BV6 = MK_6 (1, 0, 0, 1, 1, 0) => S1 (BV6) = MK_4 (1, 0, 0, 0);
BV6 = MK_6 (1, 0, 1, 0, 0, 0) => S1 (BV6) = MK_4 (1, 1, 0, 1);
BV6 = MK_6 (1, 0, 1, 0, 1, 0) => S1 (BV6) = MK_4 (0, 1, 1, 0);
BV6 = MK_6 (1, 0, 1, 1, 0, 0) => S1 (BV6) = MK_4 (0, 0, 1, 0);
BV6 = MK_6 (1, 0, 1, 1, 1, 0) => S1 (BV6) = MK_4 (1, 0, 1, 1);
BV6 = MK_6 (1, 1, 0, 0, 0, 0) => S1 (BV6) = MK_4 (1, 1, 1, 1);
BV6 = MK_6 (1, 1, 0, 0, 1, 0) => S1 (BV6) = MK_4 (1, 1, 0, 0);
BV6 = MK_6 (1, 1, 0, 1, 0, 0) => S1 (BV6) = MK_4 (1, 0, 0, 1);
BV6 = MK_6 (1, 1, 0, 1, 1, 0) => S1 (BV6) = MK_4 (0, 1, 1, 1);
BV6 = MK_6 (1, 1, 1, 0, 0, 0) => S1 (BV6) = MK_4 (0, 0, 1, 1);
BV6 = MK_6 (1, 1, 1, 0, 1, 0) => S1 (BV6) = MK_4 (1, 0, 1, 0);
BV6 = MK_6 (1, 1, 1, 1, 0, 0) => S1 (BV6) = MK_4 (0, 1, 0, 1);
BV6 = MK_6 (1, 1, 1, 1, 1, 0) => S1 (BV6) = MK_4 (0, 0, 0, 0);
BV6 = MK_6 (1, 0, 0, 0, 0, 1) => S1 (BV6) = MK_4 (1, 1, 1, 1);
BV6 = MK_6 (1, 0, 0, 0, 1, 1) => S1 (BV6) = MK_4 (1, 1, 0, 0);
BV6 = MK_6 (1, 0, 0, 1, 0, 1) => S1 (BV6) = MK_4 (1, 0, 0, 0);
BV6 = MK_6 (1, 0, 0, 1, 1, 1) => S1 (BV6) = MK_4 (0, 0, 1, 0);
BV6 = MK_6 (1, 0, 1, 0, 0, 1) => S1 (BV6) = MK_4 (0, 1, 0, 0);
BV6 = MK_6 (1, 0, 1, 0, 1, 1) => S1 (BV6) = MK_4 (1, 0, 0, 1);
BV6 = MK_6 (1, 0, 1, 1, 0, 1) => S1 (BV6) = MK_4 (0, 0, 0, 1);
BV6 = MK_6 (1, 0, 1, 1, 1, 1) => S1 (BV6) = MK_4 (0, 1, 1, 1);
BV6 = MK_6 (1, 1, 0, 0, 0, 1) => S1 (BV6) = MK_4 (0, 1, 0, 1);
BV6 = MK_6 (1, 1, 0, 0, 1, 1) => S1 (BV6) = MK_4 (1, 0, 1, 1);
BV6 = MK_6 (1, 1, 0, 1, 0, 1) => S1 (BV6) = MK_4 (0, 0, 1, 1);
BV6 = MK_6 (1, 1, 0, 1, 1, 1) => S1 (BV6) = MK_4 (1, 1, 1, 0);
BV6 = MK_6 (1, 1, 1, 0, 0, 1) => S1 (BV6) = MK_4 (1, 0, 1, 0);
BV6 = MK_6 (1, 1, 1, 0, 1, 1) => S1 (BV6) = MK_4 (0, 0, 0, 0);
BV6 = MK_6 (1, 1, 1, 1, 0, 1) => S1 (BV6) = MK_4 (0, 1, 1, 0);
BV6 = MK_6 (1, 1, 1, 1, 1, 1) => S1 (BV6) = MK_4 (1, 1, 0, 1);
ofsort BIT4
BV6 = MK_6 (0, 0, 0, 0, 0, 0) => S2 (BV6) = MK_4 (1, 1, 1, 1);
BV6 = MK_6 (0, 0, 0, 0, 1, 0) => S2 (BV6) = MK_4 (0, 0, 0, 1);
BV6 = MK_6 (0, 0, 0, 1, 0, 0) => S2 (BV6) = MK_4 (1, 0, 0, 0);
BV6 = MK_6 (0, 0, 0, 1, 1, 0) => S2 (BV6) = MK_4 (1, 1, 1, 0);
BV6 = MK_6 (0, 0, 1, 0, 0, 0) => S2 (BV6) = MK_4 (0, 1, 1, 0);
BV6 = MK_6 (0, 0, 1, 0, 1, 0) => S2 (BV6) = MK_4 (1, 0, 1, 1);
BV6 = MK_6 (0, 0, 1, 1, 0, 0) => S2 (BV6) = MK_4 (0, 0, 1, 1);
BV6 = MK_6 (0, 0, 1, 1, 1, 0) => S2 (BV6) = MK_4 (0, 1, 0, 0);
BV6 = MK_6 (0, 1, 0, 0, 0, 0) => S2 (BV6) = MK_4 (1, 0, 0, 1);
BV6 = MK_6 (0, 1, 0, 0, 1, 0) => S2 (BV6) = MK_4 (0, 1, 1, 1);
BV6 = MK_6 (0, 1, 0, 1, 0, 0) => S2 (BV6) = MK_4 (0, 0, 1, 0);
BV6 = MK_6 (0, 1, 0, 1, 1, 0) => S2 (BV6) = MK_4 (1, 1, 0, 1);
BV6 = MK_6 (0, 1, 1, 0, 0, 0) => S2 (BV6) = MK_4 (1, 1, 0, 0);
BV6 = MK_6 (0, 1, 1, 0, 1, 0) => S2 (BV6) = MK_4 (0, 0, 0, 0);

```

BV6 = MK_6 (0, 1, 1, 1, 0, 0) \Rightarrow S2 (BV6) = MK_4 (0, 1, 0, 1);
 BV6 = MK_6 (0, 1, 1, 1, 1, 0) \Rightarrow S2 (BV6) = MK_4 (1, 0, 1, 0);
 BV6 = MK_6 (0, 0, 0, 0, 0, 1) \Rightarrow S2 (BV6) = MK_4 (0, 0, 1, 1);
 BV6 = MK_6 (0, 0, 0, 0, 1, 1) \Rightarrow S2 (BV6) = MK_4 (1, 1, 0, 1);
 BV6 = MK_6 (0, 0, 0, 1, 0, 1) \Rightarrow S2 (BV6) = MK_4 (0, 1, 0, 0);
 BV6 = MK_6 (0, 0, 0, 1, 1, 1) \Rightarrow S2 (BV6) = MK_4 (0, 1, 1, 1);
 BV6 = MK_6 (0, 0, 1, 0, 0, 1) \Rightarrow S2 (BV6) = MK_4 (1, 1, 1, 1);
 BV6 = MK_6 (0, 0, 1, 0, 1, 1) \Rightarrow S2 (BV6) = MK_4 (0, 0, 1, 0);
 BV6 = MK_6 (0, 0, 1, 1, 0, 1) \Rightarrow S2 (BV6) = MK_4 (1, 0, 0, 0);
 BV6 = MK_6 (0, 0, 1, 1, 1, 1) \Rightarrow S2 (BV6) = MK_4 (1, 1, 1, 0);
 BV6 = MK_6 (0, 1, 0, 0, 0, 1) \Rightarrow S2 (BV6) = MK_4 (1, 1, 0, 0);
 BV6 = MK_6 (0, 1, 0, 0, 1, 1) \Rightarrow S2 (BV6) = MK_4 (0, 0, 0, 0);
 BV6 = MK_6 (0, 1, 0, 1, 0, 1) \Rightarrow S2 (BV6) = MK_4 (0, 0, 0, 1);
 BV6 = MK_6 (0, 1, 0, 1, 1, 1) \Rightarrow S2 (BV6) = MK_4 (1, 0, 1, 0);
 BV6 = MK_6 (0, 1, 1, 0, 0, 1) \Rightarrow S2 (BV6) = MK_4 (0, 1, 1, 0);
 BV6 = MK_6 (0, 1, 1, 0, 1, 1) \Rightarrow S2 (BV6) = MK_4 (1, 0, 0, 1);
 BV6 = MK_6 (0, 1, 1, 1, 0, 1) \Rightarrow S2 (BV6) = MK_4 (1, 0, 1, 1);
 BV6 = MK_6 (0, 1, 1, 1, 1, 1) \Rightarrow S2 (BV6) = MK_4 (0, 1, 0, 1);
 BV6 = MK_6 (1, 0, 0, 0, 0, 0) \Rightarrow S2 (BV6) = MK_4 (0, 0, 0, 0);
 BV6 = MK_6 (1, 0, 0, 0, 1, 0) \Rightarrow S2 (BV6) = MK_4 (1, 1, 1, 0);
 BV6 = MK_6 (1, 0, 0, 1, 0, 0) \Rightarrow S2 (BV6) = MK_4 (0, 1, 1, 1);
 BV6 = MK_6 (1, 0, 0, 1, 1, 0) \Rightarrow S2 (BV6) = MK_4 (1, 0, 1, 1);
 BV6 = MK_6 (1, 0, 1, 0, 0, 0) \Rightarrow S2 (BV6) = MK_4 (1, 0, 1, 0);
 BV6 = MK_6 (1, 0, 1, 0, 1, 0) \Rightarrow S2 (BV6) = MK_4 (0, 1, 0, 0);
 BV6 = MK_6 (1, 0, 1, 1, 0, 0) \Rightarrow S2 (BV6) = MK_4 (1, 1, 0, 1);
 BV6 = MK_6 (1, 0, 1, 1, 1, 0) \Rightarrow S2 (BV6) = MK_4 (0, 0, 0, 1);
 BV6 = MK_6 (1, 1, 0, 0, 0, 0) \Rightarrow S2 (BV6) = MK_4 (0, 1, 0, 1);
 BV6 = MK_6 (1, 1, 0, 0, 1, 0) \Rightarrow S2 (BV6) = MK_4 (1, 0, 0, 0);
 BV6 = MK_6 (1, 1, 0, 1, 0, 0) \Rightarrow S2 (BV6) = MK_4 (1, 1, 0, 0);
 BV6 = MK_6 (1, 1, 0, 1, 1, 0) \Rightarrow S2 (BV6) = MK_4 (0, 1, 1, 0);
 BV6 = MK_6 (1, 1, 1, 0, 0, 0) \Rightarrow S2 (BV6) = MK_4 (1, 0, 0, 1);
 BV6 = MK_6 (1, 1, 1, 0, 1, 0) \Rightarrow S2 (BV6) = MK_4 (0, 0, 1, 1);
 BV6 = MK_6 (1, 1, 1, 1, 0, 0) \Rightarrow S2 (BV6) = MK_4 (0, 0, 1, 0);
 BV6 = MK_6 (1, 1, 1, 1, 1, 0) \Rightarrow S2 (BV6) = MK_4 (1, 1, 1, 1);
 BV6 = MK_6 (1, 0, 0, 0, 0, 1) \Rightarrow S2 (BV6) = MK_4 (1, 1, 0, 1);
 BV6 = MK_6 (1, 0, 0, 0, 1, 1) \Rightarrow S2 (BV6) = MK_4 (1, 0, 0, 0);
 BV6 = MK_6 (1, 0, 0, 1, 0, 1) \Rightarrow S2 (BV6) = MK_4 (1, 0, 1, 0);
 BV6 = MK_6 (1, 0, 0, 1, 1, 1) \Rightarrow S2 (BV6) = MK_4 (0, 0, 0, 1);
 BV6 = MK_6 (1, 0, 1, 0, 0, 1) \Rightarrow S2 (BV6) = MK_4 (0, 0, 1, 1);
 BV6 = MK_6 (1, 0, 1, 0, 1, 1) \Rightarrow S2 (BV6) = MK_4 (1, 1, 1, 1);
 BV6 = MK_6 (1, 0, 1, 1, 0, 1) \Rightarrow S2 (BV6) = MK_4 (0, 1, 0, 0);
 BV6 = MK_6 (1, 0, 1, 1, 1, 1) \Rightarrow S2 (BV6) = MK_4 (0, 0, 1, 0);
 BV6 = MK_6 (1, 1, 0, 0, 0, 1) \Rightarrow S2 (BV6) = MK_4 (1, 0, 1, 1);
 BV6 = MK_6 (1, 1, 0, 0, 1, 1) \Rightarrow S2 (BV6) = MK_4 (0, 1, 1, 0);
 BV6 = MK_6 (1, 1, 0, 1, 0, 1) \Rightarrow S2 (BV6) = MK_4 (0, 1, 1, 1);
 BV6 = MK_6 (1, 1, 0, 1, 1, 1) \Rightarrow S2 (BV6) = MK_4 (1, 1, 0, 0);
 BV6 = MK_6 (1, 1, 1, 0, 0, 1) \Rightarrow S2 (BV6) = MK_4 (0, 0, 0, 0);
 BV6 = MK_6 (1, 1, 1, 0, 1, 1) \Rightarrow S2 (BV6) = MK_4 (0, 1, 0, 1);
 BV6 = MK_6 (1, 1, 1, 1, 0, 1) \Rightarrow S2 (BV6) = MK_4 (1, 1, 1, 0);
 BV6 = MK_6 (1, 1, 1, 1, 1, 1) \Rightarrow S2 (BV6) = MK_4 (1, 0, 0, 1);
ofsort BIT4
 BV6 = MK_6 (0, 0, 0, 0, 0, 0) \Rightarrow S3 (BV6) = MK_4 (1, 0, 1, 0);

BV6 = MK_6 (0, 0, 0, 0, 1, 0) ⇒ S3 (BV6) = MK_4 (0, 0, 0, 0);
 BV6 = MK_6 (0, 0, 0, 1, 0, 0) ⇒ S3 (BV6) = MK_4 (1, 0, 0, 1);
 BV6 = MK_6 (0, 0, 0, 1, 1, 0) ⇒ S3 (BV6) = MK_4 (1, 1, 1, 0);
 BV6 = MK_6 (0, 0, 1, 0, 0, 0) ⇒ S3 (BV6) = MK_4 (0, 1, 1, 0);
 BV6 = MK_6 (0, 0, 1, 0, 1, 0) ⇒ S3 (BV6) = MK_4 (0, 0, 1, 1);
 BV6 = MK_6 (0, 0, 1, 1, 0, 0) ⇒ S3 (BV6) = MK_4 (1, 1, 1, 1);
 BV6 = MK_6 (0, 0, 1, 1, 1, 0) ⇒ S3 (BV6) = MK_4 (0, 1, 0, 1);
 BV6 = MK_6 (0, 1, 0, 0, 0, 0) ⇒ S3 (BV6) = MK_4 (0, 0, 0, 1);
 BV6 = MK_6 (0, 1, 0, 0, 1, 0) ⇒ S3 (BV6) = MK_4 (1, 1, 0, 1);
 BV6 = MK_6 (0, 1, 0, 1, 0, 0) ⇒ S3 (BV6) = MK_4 (1, 1, 0, 0);
 BV6 = MK_6 (0, 1, 0, 1, 1, 0) ⇒ S3 (BV6) = MK_4 (0, 1, 1, 1);
 BV6 = MK_6 (0, 1, 1, 0, 0, 0) ⇒ S3 (BV6) = MK_4 (1, 0, 1, 1);
 BV6 = MK_6 (0, 1, 1, 0, 1, 0) ⇒ S3 (BV6) = MK_4 (0, 1, 0, 0);
 BV6 = MK_6 (0, 1, 1, 1, 0, 0) ⇒ S3 (BV6) = MK_4 (0, 0, 1, 0);
 BV6 = MK_6 (0, 1, 1, 1, 1, 0) ⇒ S3 (BV6) = MK_4 (1, 0, 0, 0);
 BV6 = MK_6 (0, 0, 0, 0, 0, 1) ⇒ S3 (BV6) = MK_4 (1, 1, 0, 1);
 BV6 = MK_6 (0, 0, 0, 0, 1, 1) ⇒ S3 (BV6) = MK_4 (0, 1, 1, 1);
 BV6 = MK_6 (0, 0, 0, 1, 0, 1) ⇒ S3 (BV6) = MK_4 (0, 0, 0, 0);
 BV6 = MK_6 (0, 0, 0, 1, 1, 1) ⇒ S3 (BV6) = MK_4 (1, 0, 0, 1);
 BV6 = MK_6 (0, 0, 1, 0, 0, 1) ⇒ S3 (BV6) = MK_4 (0, 0, 1, 1);
 BV6 = MK_6 (0, 0, 1, 0, 1, 1) ⇒ S3 (BV6) = MK_4 (0, 1, 0, 0);
 BV6 = MK_6 (0, 0, 1, 1, 0, 1) ⇒ S3 (BV6) = MK_4 (0, 1, 1, 0);
 BV6 = MK_6 (0, 0, 1, 1, 1, 1) ⇒ S3 (BV6) = MK_4 (1, 0, 1, 0);
 BV6 = MK_6 (0, 1, 0, 0, 0, 1) ⇒ S3 (BV6) = MK_4 (0, 0, 1, 0);
 BV6 = MK_6 (0, 1, 0, 0, 1, 1) ⇒ S3 (BV6) = MK_4 (1, 0, 0, 0);
 BV6 = MK_6 (0, 1, 0, 1, 0, 1) ⇒ S3 (BV6) = MK_4 (0, 1, 0, 1);
 BV6 = MK_6 (0, 1, 0, 1, 1, 1) ⇒ S3 (BV6) = MK_4 (1, 1, 1, 0);
 BV6 = MK_6 (0, 1, 1, 0, 0, 1) ⇒ S3 (BV6) = MK_4 (1, 1, 0, 0);
 BV6 = MK_6 (0, 1, 1, 0, 1, 1) ⇒ S3 (BV6) = MK_4 (1, 0, 1, 1);
 BV6 = MK_6 (0, 1, 1, 1, 0, 1) ⇒ S3 (BV6) = MK_4 (1, 1, 1, 1);
 BV6 = MK_6 (0, 1, 1, 1, 1, 1) ⇒ S3 (BV6) = MK_4 (0, 0, 0, 1);
 BV6 = MK_6 (1, 0, 0, 0, 0, 0) ⇒ S3 (BV6) = MK_4 (1, 1, 0, 1);
 BV6 = MK_6 (1, 0, 0, 0, 1, 0) ⇒ S3 (BV6) = MK_4 (0, 1, 1, 0);
 BV6 = MK_6 (1, 0, 0, 1, 0, 0) ⇒ S3 (BV6) = MK_4 (0, 1, 0, 0);
 BV6 = MK_6 (1, 0, 0, 1, 1, 0) ⇒ S3 (BV6) = MK_4 (1, 0, 0, 1);
 BV6 = MK_6 (1, 0, 1, 0, 0, 0) ⇒ S3 (BV6) = MK_4 (1, 0, 0, 0);
 BV6 = MK_6 (1, 0, 1, 0, 1, 0) ⇒ S3 (BV6) = MK_4 (1, 1, 1, 1);
 BV6 = MK_6 (1, 0, 1, 1, 0, 0) ⇒ S3 (BV6) = MK_4 (0, 0, 1, 1);
 BV6 = MK_6 (1, 0, 1, 1, 1, 0) ⇒ S3 (BV6) = MK_4 (0, 0, 0, 0);
 BV6 = MK_6 (1, 1, 0, 0, 0, 0) ⇒ S3 (BV6) = MK_4 (1, 0, 1, 1);
 BV6 = MK_6 (1, 1, 0, 0, 1, 0) ⇒ S3 (BV6) = MK_4 (0, 0, 0, 1);
 BV6 = MK_6 (1, 1, 0, 1, 0, 0) ⇒ S3 (BV6) = MK_4 (0, 0, 1, 0);
 BV6 = MK_6 (1, 1, 0, 1, 1, 0) ⇒ S3 (BV6) = MK_4 (1, 1, 0, 0);
 BV6 = MK_6 (1, 1, 1, 0, 0, 0) ⇒ S3 (BV6) = MK_4 (0, 1, 0, 1);
 BV6 = MK_6 (1, 1, 1, 0, 1, 0) ⇒ S3 (BV6) = MK_4 (1, 0, 1, 0);
 BV6 = MK_6 (1, 1, 1, 1, 0, 0) ⇒ S3 (BV6) = MK_4 (1, 1, 1, 0);
 BV6 = MK_6 (1, 1, 1, 1, 1, 0) ⇒ S3 (BV6) = MK_4 (0, 1, 1, 1);
 BV6 = MK_6 (1, 0, 0, 0, 0, 1) ⇒ S3 (BV6) = MK_4 (0, 0, 0, 1);
 BV6 = MK_6 (1, 0, 0, 0, 1, 1) ⇒ S3 (BV6) = MK_4 (1, 0, 1, 0);
 BV6 = MK_6 (1, 0, 0, 1, 0, 1) ⇒ S3 (BV6) = MK_4 (1, 0, 1, 1);
 BV6 = MK_6 (1, 0, 0, 1, 1, 1) ⇒ S3 (BV6) = MK_4 (0, 0, 0, 0);
 BV6 = MK_6 (1, 0, 1, 0, 0, 1) ⇒ S3 (BV6) = MK_4 (0, 1, 1, 0);

```

BV6 = MK_6 (1, 0, 1, 0, 1, 1) => S3 (BV6) = MK_4 (1, 0, 0, 1);
BV6 = MK_6 (1, 0, 1, 1, 0, 1) => S3 (BV6) = MK_4 (1, 0, 0, 0);
BV6 = MK_6 (1, 0, 1, 1, 1, 1) => S3 (BV6) = MK_4 (0, 1, 1, 1);
BV6 = MK_6 (1, 1, 0, 0, 0, 1) => S3 (BV6) = MK_4 (0, 1, 0, 0);
BV6 = MK_6 (1, 1, 0, 0, 1, 1) => S3 (BV6) = MK_4 (1, 1, 1, 1);
BV6 = MK_6 (1, 1, 0, 1, 0, 1) => S3 (BV6) = MK_4 (1, 1, 1, 0);
BV6 = MK_6 (1, 1, 0, 1, 1, 1) => S3 (BV6) = MK_4 (0, 0, 1, 1);
BV6 = MK_6 (1, 1, 1, 0, 0, 1) => S3 (BV6) = MK_4 (1, 0, 1, 1);
BV6 = MK_6 (1, 1, 1, 0, 1, 1) => S3 (BV6) = MK_4 (0, 1, 0, 1);
BV6 = MK_6 (1, 1, 1, 1, 0, 1) => S3 (BV6) = MK_4 (0, 0, 1, 0);
BV6 = MK_6 (1, 1, 1, 1, 1, 1) => S3 (BV6) = MK_4 (1, 1, 0, 0);
ofsort BIT4
BV6 = MK_6 (0, 0, 0, 0, 0, 0) => S4 (BV6) = MK_4 (0, 1, 1, 1);
BV6 = MK_6 (0, 0, 0, 0, 1, 0) => S4 (BV6) = MK_4 (1, 1, 0, 1);
BV6 = MK_6 (0, 0, 0, 1, 0, 0) => S4 (BV6) = MK_4 (1, 1, 1, 0);
BV6 = MK_6 (0, 0, 0, 1, 1, 0) => S4 (BV6) = MK_4 (0, 0, 1, 1);
BV6 = MK_6 (0, 0, 1, 0, 0, 0) => S4 (BV6) = MK_4 (0, 0, 0, 0);
BV6 = MK_6 (0, 0, 1, 0, 1, 0) => S4 (BV6) = MK_4 (0, 1, 1, 0);
BV6 = MK_6 (0, 0, 1, 1, 0, 0) => S4 (BV6) = MK_4 (1, 0, 0, 1);
BV6 = MK_6 (0, 0, 1, 1, 1, 0) => S4 (BV6) = MK_4 (1, 0, 1, 0);
BV6 = MK_6 (0, 1, 0, 0, 0, 0) => S4 (BV6) = MK_4 (0, 0, 0, 1);
BV6 = MK_6 (0, 1, 0, 0, 1, 0) => S4 (BV6) = MK_4 (0, 0, 1, 0);
BV6 = MK_6 (0, 1, 0, 1, 0, 0) => S4 (BV6) = MK_4 (1, 0, 0, 0);
BV6 = MK_6 (0, 1, 0, 1, 1, 0) => S4 (BV6) = MK_4 (0, 1, 0, 1);
BV6 = MK_6 (0, 1, 1, 0, 0, 0) => S4 (BV6) = MK_4 (1, 0, 1, 1);
BV6 = MK_6 (0, 1, 1, 0, 1, 0) => S4 (BV6) = MK_4 (1, 1, 0, 0);
BV6 = MK_6 (0, 1, 1, 1, 0, 0) => S4 (BV6) = MK_4 (0, 1, 0, 0);
BV6 = MK_6 (0, 1, 1, 1, 1, 0) => S4 (BV6) = MK_4 (1, 1, 1, 1);
BV6 = MK_6 (0, 0, 0, 0, 0, 1) => S4 (BV6) = MK_4 (1, 1, 0, 1);
BV6 = MK_6 (0, 0, 0, 0, 1, 1) => S4 (BV6) = MK_4 (1, 0, 0, 0);
BV6 = MK_6 (0, 0, 0, 1, 0, 1) => S4 (BV6) = MK_4 (1, 0, 1, 1);
BV6 = MK_6 (0, 0, 0, 1, 1, 1) => S4 (BV6) = MK_4 (0, 1, 0, 1);
BV6 = MK_6 (0, 0, 1, 0, 0, 1) => S4 (BV6) = MK_4 (0, 1, 1, 0);
BV6 = MK_6 (0, 0, 1, 0, 1, 1) => S4 (BV6) = MK_4 (1, 1, 1, 1);
BV6 = MK_6 (0, 0, 1, 1, 0, 1) => S4 (BV6) = MK_4 (0, 0, 0, 0);
BV6 = MK_6 (0, 0, 1, 1, 1, 1) => S4 (BV6) = MK_4 (0, 0, 1, 1);
BV6 = MK_6 (0, 1, 0, 0, 0, 1) => S4 (BV6) = MK_4 (0, 1, 0, 0);
BV6 = MK_6 (0, 1, 0, 0, 1, 1) => S4 (BV6) = MK_4 (0, 1, 1, 1);
BV6 = MK_6 (0, 1, 0, 1, 0, 1) => S4 (BV6) = MK_4 (0, 0, 1, 0);
BV6 = MK_6 (0, 1, 0, 1, 1, 1) => S4 (BV6) = MK_4 (1, 1, 0, 0);
BV6 = MK_6 (0, 1, 1, 0, 0, 1) => S4 (BV6) = MK_4 (0, 0, 0, 1);
BV6 = MK_6 (0, 1, 1, 0, 1, 1) => S4 (BV6) = MK_4 (1, 0, 1, 0);
BV6 = MK_6 (0, 1, 1, 1, 0, 1) => S4 (BV6) = MK_4 (1, 1, 1, 0);
BV6 = MK_6 (0, 1, 1, 1, 1, 1) => S4 (BV6) = MK_4 (1, 0, 0, 1);
BV6 = MK_6 (1, 0, 0, 0, 0, 0) => S4 (BV6) = MK_4 (1, 0, 1, 0);
BV6 = MK_6 (1, 0, 0, 0, 1, 0) => S4 (BV6) = MK_4 (0, 1, 1, 0);
BV6 = MK_6 (1, 0, 0, 1, 0, 0) => S4 (BV6) = MK_4 (1, 0, 0, 1);
BV6 = MK_6 (1, 0, 0, 1, 1, 0) => S4 (BV6) = MK_4 (0, 0, 0, 0);
BV6 = MK_6 (1, 0, 1, 0, 0, 0) => S4 (BV6) = MK_4 (1, 1, 0, 0);
BV6 = MK_6 (1, 0, 1, 0, 1, 0) => S4 (BV6) = MK_4 (1, 0, 1, 1);
BV6 = MK_6 (1, 0, 1, 1, 0, 0) => S4 (BV6) = MK_4 (0, 1, 1, 1);
BV6 = MK_6 (1, 0, 1, 1, 1, 0) => S4 (BV6) = MK_4 (1, 1, 0, 1);

```

```

BV6 = MK_6 (1, 1, 0, 0, 0, 0) => S4 (BV6) = MK_4 (1, 1, 1, 1);
BV6 = MK_6 (1, 1, 0, 0, 1, 0) => S4 (BV6) = MK_4 (0, 0, 0, 1);
BV6 = MK_6 (1, 1, 0, 1, 0, 0) => S4 (BV6) = MK_4 (0, 0, 1, 1);
BV6 = MK_6 (1, 1, 0, 1, 1, 0) => S4 (BV6) = MK_4 (1, 1, 1, 0);
BV6 = MK_6 (1, 1, 1, 0, 0, 0) => S4 (BV6) = MK_4 (0, 1, 0, 1);
BV6 = MK_6 (1, 1, 1, 0, 1, 0) => S4 (BV6) = MK_4 (0, 0, 1, 0);
BV6 = MK_6 (1, 1, 1, 1, 0, 0) => S4 (BV6) = MK_4 (1, 0, 0, 0);
BV6 = MK_6 (1, 1, 1, 1, 1, 0) => S4 (BV6) = MK_4 (0, 1, 0, 0);
BV6 = MK_6 (1, 0, 0, 0, 0, 1) => S4 (BV6) = MK_4 (0, 0, 1, 1);
BV6 = MK_6 (1, 0, 0, 0, 1, 1) => S4 (BV6) = MK_4 (1, 1, 1, 1);
BV6 = MK_6 (1, 0, 0, 1, 0, 1) => S4 (BV6) = MK_4 (0, 0, 0, 0);
BV6 = MK_6 (1, 0, 0, 1, 1, 1) => S4 (BV6) = MK_4 (0, 1, 1, 0);
BV6 = MK_6 (1, 0, 1, 0, 0, 1) => S4 (BV6) = MK_4 (1, 0, 1, 0);
BV6 = MK_6 (1, 0, 1, 0, 1, 1) => S4 (BV6) = MK_4 (0, 0, 0, 1);
BV6 = MK_6 (1, 0, 1, 1, 0, 1) => S4 (BV6) = MK_4 (1, 1, 0, 1);
BV6 = MK_6 (1, 0, 1, 1, 1, 1) => S4 (BV6) = MK_4 (1, 0, 0, 0);
BV6 = MK_6 (1, 1, 0, 0, 0, 1) => S4 (BV6) = MK_4 (1, 0, 0, 1);
BV6 = MK_6 (1, 1, 0, 0, 1, 1) => S4 (BV6) = MK_4 (0, 1, 0, 0);
BV6 = MK_6 (1, 1, 0, 1, 0, 1) => S4 (BV6) = MK_4 (0, 1, 0, 1);
BV6 = MK_6 (1, 1, 0, 1, 1, 1) => S4 (BV6) = MK_4 (1, 0, 1, 1);
BV6 = MK_6 (1, 1, 1, 0, 0, 1) => S4 (BV6) = MK_4 (1, 1, 0, 0);
BV6 = MK_6 (1, 1, 1, 0, 1, 1) => S4 (BV6) = MK_4 (0, 1, 1, 1);
BV6 = MK_6 (1, 1, 1, 1, 0, 1) => S4 (BV6) = MK_4 (0, 0, 1, 0);
BV6 = MK_6 (1, 1, 1, 1, 1, 1) => S4 (BV6) = MK_4 (1, 1, 1, 0);
ofsort BIT4
BV6 = MK_6 (0, 0, 0, 0, 0, 0) => S5 (BV6) = MK_4 (0, 0, 1, 0);
BV6 = MK_6 (0, 0, 0, 0, 1, 0) => S5 (BV6) = MK_4 (1, 1, 0, 0);
BV6 = MK_6 (0, 0, 0, 1, 0, 0) => S5 (BV6) = MK_4 (0, 1, 0, 0);
BV6 = MK_6 (0, 0, 0, 1, 1, 0) => S5 (BV6) = MK_4 (0, 0, 0, 1);
BV6 = MK_6 (0, 0, 1, 0, 0, 0) => S5 (BV6) = MK_4 (0, 1, 1, 1);
BV6 = MK_6 (0, 0, 1, 0, 1, 0) => S5 (BV6) = MK_4 (1, 0, 1, 0);
BV6 = MK_6 (0, 0, 1, 1, 0, 0) => S5 (BV6) = MK_4 (1, 0, 1, 1);
BV6 = MK_6 (0, 0, 1, 1, 1, 0) => S5 (BV6) = MK_4 (0, 1, 1, 0);
BV6 = MK_6 (0, 1, 0, 0, 0, 0) => S5 (BV6) = MK_4 (1, 0, 0, 0);
BV6 = MK_6 (0, 1, 0, 0, 1, 0) => S5 (BV6) = MK_4 (0, 1, 0, 1);
BV6 = MK_6 (0, 1, 0, 1, 0, 0) => S5 (BV6) = MK_4 (0, 0, 1, 1);
BV6 = MK_6 (0, 1, 0, 1, 1, 0) => S5 (BV6) = MK_4 (1, 1, 1, 1);
BV6 = MK_6 (0, 1, 1, 0, 0, 0) => S5 (BV6) = MK_4 (1, 1, 0, 1);
BV6 = MK_6 (0, 1, 1, 0, 1, 0) => S5 (BV6) = MK_4 (0, 0, 0, 0);
BV6 = MK_6 (0, 1, 1, 1, 0, 0) => S5 (BV6) = MK_4 (1, 1, 1, 0);
BV6 = MK_6 (0, 1, 1, 1, 1, 0) => S5 (BV6) = MK_4 (1, 0, 0, 1);
BV6 = MK_6 (0, 0, 0, 0, 0, 1) => S5 (BV6) = MK_4 (1, 1, 0, 0);
BV6 = MK_6 (0, 0, 0, 0, 1, 1) => S5 (BV6) = MK_4 (1, 0, 1, 1);
BV6 = MK_6 (0, 0, 0, 1, 0, 1) => S5 (BV6) = MK_4 (0, 0, 1, 0);
BV6 = MK_6 (0, 0, 0, 1, 1, 1) => S5 (BV6) = MK_4 (1, 1, 0, 0);
BV6 = MK_6 (0, 0, 1, 0, 0, 1) => S5 (BV6) = MK_4 (0, 1, 0, 0);
BV6 = MK_6 (0, 0, 1, 0, 1, 1) => S5 (BV6) = MK_4 (0, 1, 1, 1);
BV6 = MK_6 (0, 0, 1, 1, 0, 1) => S5 (BV6) = MK_4 (1, 1, 0, 1);
BV6 = MK_6 (0, 0, 1, 1, 1, 1) => S5 (BV6) = MK_4 (0, 0, 0, 1);
BV6 = MK_6 (0, 1, 0, 0, 0, 1) => S5 (BV6) = MK_4 (0, 1, 0, 1);
BV6 = MK_6 (0, 1, 0, 0, 1, 1) => S5 (BV6) = MK_4 (0, 0, 0, 0);
BV6 = MK_6 (0, 1, 0, 1, 0, 1) => S5 (BV6) = MK_4 (1, 1, 1, 1);

```

```

BV6 = MK_6 (0, 1, 0, 1, 1, 1) => S5 (BV6) = MK_4 (1, 0, 1, 0);
BV6 = MK_6 (0, 1, 1, 0, 0, 1) => S5 (BV6) = MK_4 (0, 0, 1, 1);
BV6 = MK_6 (0, 1, 1, 0, 1, 1) => S5 (BV6) = MK_4 (1, 0, 0, 1);
BV6 = MK_6 (0, 1, 1, 1, 0, 1) => S5 (BV6) = MK_4 (1, 0, 0, 0);
BV6 = MK_6 (0, 1, 1, 1, 1, 1) => S5 (BV6) = MK_4 (0, 1, 1, 0);
BV6 = MK_6 (1, 0, 0, 0, 0, 0) => S5 (BV6) = MK_4 (0, 1, 0, 0);
BV6 = MK_6 (1, 0, 0, 0, 1, 0) => S5 (BV6) = MK_4 (0, 0, 1, 0);
BV6 = MK_6 (1, 0, 0, 1, 0, 0) => S5 (BV6) = MK_4 (0, 0, 0, 1);
BV6 = MK_6 (1, 0, 0, 1, 1, 0) => S5 (BV6) = MK_4 (1, 0, 1, 1);
BV6 = MK_6 (1, 0, 1, 0, 0, 0) => S5 (BV6) = MK_4 (1, 0, 1, 0);
BV6 = MK_6 (1, 0, 1, 0, 1, 0) => S5 (BV6) = MK_4 (1, 1, 0, 1);
BV6 = MK_6 (1, 0, 1, 1, 0, 0) => S5 (BV6) = MK_4 (0, 1, 1, 1);
BV6 = MK_6 (1, 0, 1, 1, 1, 0) => S5 (BV6) = MK_4 (1, 0, 0, 0);
BV6 = MK_6 (1, 1, 0, 0, 0, 0) => S5 (BV6) = MK_4 (1, 1, 1, 1);
BV6 = MK_6 (1, 1, 0, 0, 1, 0) => S5 (BV6) = MK_4 (1, 0, 0, 1);
BV6 = MK_6 (1, 1, 0, 1, 0, 0) => S5 (BV6) = MK_4 (1, 1, 0, 0);
BV6 = MK_6 (1, 1, 0, 1, 1, 0) => S5 (BV6) = MK_4 (0, 1, 0, 1);
BV6 = MK_6 (1, 1, 1, 0, 0, 0) => S5 (BV6) = MK_4 (0, 1, 1, 0);
BV6 = MK_6 (1, 1, 1, 0, 1, 0) => S5 (BV6) = MK_4 (0, 0, 1, 1);
BV6 = MK_6 (1, 1, 1, 1, 0, 0) => S5 (BV6) = MK_4 (0, 0, 0, 0);
BV6 = MK_6 (1, 1, 1, 1, 1, 0) => S5 (BV6) = MK_4 (1, 1, 1, 0);
BV6 = MK_6 (1, 0, 0, 0, 0, 1) => S5 (BV6) = MK_4 (1, 0, 1, 1);
BV6 = MK_6 (1, 0, 0, 0, 1, 1) => S5 (BV6) = MK_4 (1, 0, 0, 0);
BV6 = MK_6 (1, 0, 0, 1, 0, 1) => S5 (BV6) = MK_4 (1, 1, 0, 0);
BV6 = MK_6 (1, 0, 0, 1, 1, 1) => S5 (BV6) = MK_4 (0, 1, 1, 1);
BV6 = MK_6 (1, 0, 1, 0, 0, 1) => S5 (BV6) = MK_4 (0, 0, 0, 1);
BV6 = MK_6 (1, 0, 1, 0, 1, 1) => S5 (BV6) = MK_4 (1, 1, 1, 0);
BV6 = MK_6 (1, 0, 1, 1, 0, 1) => S5 (BV6) = MK_4 (0, 0, 1, 0);
BV6 = MK_6 (1, 0, 1, 1, 1, 1) => S5 (BV6) = MK_4 (1, 1, 0, 1);
BV6 = MK_6 (1, 1, 0, 0, 0, 1) => S5 (BV6) = MK_4 (0, 1, 1, 0);
BV6 = MK_6 (1, 1, 0, 0, 1, 1) => S5 (BV6) = MK_4 (1, 1, 1, 1);
BV6 = MK_6 (1, 1, 0, 1, 0, 1) => S5 (BV6) = MK_4 (0, 0, 0, 0);
BV6 = MK_6 (1, 1, 0, 1, 1, 1) => S5 (BV6) = MK_4 (1, 0, 0, 1);
BV6 = MK_6 (1, 1, 1, 0, 0, 1) => S5 (BV6) = MK_4 (1, 0, 1, 0);
BV6 = MK_6 (1, 1, 1, 0, 1, 1) => S5 (BV6) = MK_4 (0, 1, 0, 0);
BV6 = MK_6 (1, 1, 1, 1, 0, 1) => S5 (BV6) = MK_4 (0, 1, 0, 1);
BV6 = MK_6 (1, 1, 1, 1, 1, 1) => S5 (BV6) = MK_4 (0, 0, 1, 1);
ofsort BIT4
BV6 = MK_6 (0, 0, 0, 0, 0, 0) => S6 (BV6) = MK_4 (1, 1, 0, 0);
BV6 = MK_6 (0, 0, 0, 0, 1, 0) => S6 (BV6) = MK_4 (0, 0, 0, 1);
BV6 = MK_6 (0, 0, 0, 1, 0, 0) => S6 (BV6) = MK_4 (1, 0, 1, 0);
BV6 = MK_6 (0, 0, 0, 1, 1, 0) => S6 (BV6) = MK_4 (1, 1, 1, 1);
BV6 = MK_6 (0, 0, 1, 0, 0, 0) => S6 (BV6) = MK_4 (1, 0, 0, 1);
BV6 = MK_6 (0, 0, 1, 0, 1, 0) => S6 (BV6) = MK_4 (0, 0, 1, 0);
BV6 = MK_6 (0, 0, 1, 1, 0, 0) => S6 (BV6) = MK_4 (0, 1, 1, 0);
BV6 = MK_6 (0, 0, 1, 1, 1, 0) => S6 (BV6) = MK_4 (1, 0, 0, 0);
BV6 = MK_6 (0, 1, 0, 0, 0, 0) => S6 (BV6) = MK_4 (0, 0, 0, 0);
BV6 = MK_6 (0, 1, 0, 0, 1, 0) => S6 (BV6) = MK_4 (1, 1, 0, 1);
BV6 = MK_6 (0, 1, 0, 1, 0, 0) => S6 (BV6) = MK_4 (0, 0, 1, 1);
BV6 = MK_6 (0, 1, 0, 1, 1, 0) => S6 (BV6) = MK_4 (0, 1, 0, 0);
BV6 = MK_6 (0, 1, 1, 0, 0, 0) => S6 (BV6) = MK_4 (1, 1, 1, 0);
BV6 = MK_6 (0, 1, 1, 0, 1, 0) => S6 (BV6) = MK_4 (0, 1, 1, 1);

```

```

BV6 = MK_6 (0, 1, 1, 1, 0, 0) => S6 (BV6) = MK_4 (0, 1, 0, 1);
BV6 = MK_6 (0, 1, 1, 1, 1, 0) => S6 (BV6) = MK_4 (1, 0, 1, 1);
BV6 = MK_6 (0, 0, 0, 0, 0, 1) => S6 (BV6) = MK_4 (1, 0, 1, 0);
BV6 = MK_6 (0, 0, 0, 0, 1, 1) => S6 (BV6) = MK_4 (1, 1, 1, 1);
BV6 = MK_6 (0, 0, 0, 1, 0, 1) => S6 (BV6) = MK_4 (0, 1, 0, 0);
BV6 = MK_6 (0, 0, 0, 1, 1, 1) => S6 (BV6) = MK_4 (0, 0, 1, 0);
BV6 = MK_6 (0, 0, 1, 0, 0, 1) => S6 (BV6) = MK_4 (0, 1, 1, 1);
BV6 = MK_6 (0, 0, 1, 0, 1, 1) => S6 (BV6) = MK_4 (1, 1, 0, 0);
BV6 = MK_6 (0, 0, 1, 1, 0, 1) => S6 (BV6) = MK_4 (1, 0, 0, 1);
BV6 = MK_6 (0, 0, 1, 1, 1, 1) => S6 (BV6) = MK_4 (0, 1, 0, 1);
BV6 = MK_6 (0, 1, 0, 0, 0, 1) => S6 (BV6) = MK_4 (0, 1, 1, 0);
BV6 = MK_6 (0, 1, 0, 0, 1, 1) => S6 (BV6) = MK_4 (0, 0, 0, 1);
BV6 = MK_6 (0, 1, 0, 1, 0, 1) => S6 (BV6) = MK_4 (1, 1, 0, 1);
BV6 = MK_6 (0, 1, 0, 1, 1, 1) => S6 (BV6) = MK_4 (1, 1, 1, 0);
BV6 = MK_6 (0, 1, 1, 0, 0, 1) => S6 (BV6) = MK_4 (0, 0, 0, 0);
BV6 = MK_6 (0, 1, 1, 0, 1, 1) => S6 (BV6) = MK_4 (1, 0, 1, 1);
BV6 = MK_6 (0, 1, 1, 1, 0, 1) => S6 (BV6) = MK_4 (0, 0, 1, 1);
BV6 = MK_6 (0, 1, 1, 1, 1, 1) => S6 (BV6) = MK_4 (1, 0, 0, 0);
BV6 = MK_6 (1, 0, 0, 0, 0, 0) => S6 (BV6) = MK_4 (1, 0, 0, 1);
BV6 = MK_6 (1, 0, 0, 0, 1, 0) => S6 (BV6) = MK_4 (1, 1, 1, 0);
BV6 = MK_6 (1, 0, 0, 1, 0, 0) => S6 (BV6) = MK_4 (1, 1, 1, 1);
BV6 = MK_6 (1, 0, 0, 1, 1, 0) => S6 (BV6) = MK_4 (0, 1, 0, 1);
BV6 = MK_6 (1, 0, 1, 0, 0, 0) => S6 (BV6) = MK_4 (0, 0, 1, 0);
BV6 = MK_6 (1, 0, 1, 0, 1, 0) => S6 (BV6) = MK_4 (1, 0, 0, 0);
BV6 = MK_6 (1, 0, 1, 1, 0, 0) => S6 (BV6) = MK_4 (1, 1, 0, 0);
BV6 = MK_6 (1, 0, 1, 1, 1, 0) => S6 (BV6) = MK_4 (0, 0, 1, 1);
BV6 = MK_6 (1, 1, 0, 0, 0, 0) => S6 (BV6) = MK_4 (0, 1, 1, 1);
BV6 = MK_6 (1, 1, 0, 0, 1, 0) => S6 (BV6) = MK_4 (0, 0, 0, 0);
BV6 = MK_6 (1, 1, 0, 1, 0, 0) => S6 (BV6) = MK_4 (0, 1, 0, 0);
BV6 = MK_6 (1, 1, 0, 1, 1, 0) => S6 (BV6) = MK_4 (1, 0, 1, 0);
BV6 = MK_6 (1, 1, 1, 0, 0, 0) => S6 (BV6) = MK_4 (0, 0, 0, 1);
BV6 = MK_6 (1, 1, 1, 0, 1, 0) => S6 (BV6) = MK_4 (1, 1, 0, 1);
BV6 = MK_6 (1, 1, 1, 1, 0, 0) => S6 (BV6) = MK_4 (1, 0, 1, 1);
BV6 = MK_6 (1, 1, 1, 1, 1, 0) => S6 (BV6) = MK_4 (0, 1, 1, 0);
BV6 = MK_6 (1, 0, 0, 0, 0, 1) => S6 (BV6) = MK_4 (0, 1, 0, 0);
BV6 = MK_6 (1, 0, 0, 0, 1, 1) => S6 (BV6) = MK_4 (0, 0, 1, 1);
BV6 = MK_6 (1, 0, 0, 1, 0, 1) => S6 (BV6) = MK_4 (0, 0, 1, 0);
BV6 = MK_6 (1, 0, 0, 1, 1, 1) => S6 (BV6) = MK_4 (1, 1, 0, 0);
BV6 = MK_6 (1, 0, 1, 0, 0, 1) => S6 (BV6) = MK_4 (1, 0, 0, 1);
BV6 = MK_6 (1, 0, 1, 0, 1, 1) => S6 (BV6) = MK_4 (0, 1, 0, 1);
BV6 = MK_6 (1, 0, 1, 1, 0, 1) => S6 (BV6) = MK_4 (1, 1, 1, 1);
BV6 = MK_6 (1, 0, 1, 1, 1, 1) => S6 (BV6) = MK_4 (1, 0, 1, 0);
BV6 = MK_6 (1, 1, 0, 0, 0, 1) => S6 (BV6) = MK_4 (1, 0, 1, 1);
BV6 = MK_6 (1, 1, 0, 0, 1, 1) => S6 (BV6) = MK_4 (1, 1, 1, 0);
BV6 = MK_6 (1, 1, 0, 1, 0, 1) => S6 (BV6) = MK_4 (0, 0, 0, 1);
BV6 = MK_6 (1, 1, 0, 1, 1, 1) => S6 (BV6) = MK_4 (0, 1, 1, 1);
BV6 = MK_6 (1, 1, 1, 0, 0, 1) => S6 (BV6) = MK_4 (0, 1, 1, 0);
BV6 = MK_6 (1, 1, 1, 0, 1, 1) => S6 (BV6) = MK_4 (0, 0, 0, 0);
BV6 = MK_6 (1, 1, 1, 1, 0, 1) => S6 (BV6) = MK_4 (1, 0, 0, 0);
BV6 = MK_6 (1, 1, 1, 1, 1, 1) => S6 (BV6) = MK_4 (1, 1, 0, 1);
ofsort BIT4
  BV6 = MK_6 (0, 0, 0, 0, 0, 0) => S7 (BV6) = MK_4 (0, 1, 0, 0);

```



```

BV6 = MK_6 (1, 0, 1, 0, 1, 1) => S7 (BV6) = MK_4 (0, 1, 0, 0);
BV6 = MK_6 (1, 0, 1, 1, 0, 1) => S7 (BV6) = MK_4 (1, 0, 1, 0);
BV6 = MK_6 (1, 0, 1, 1, 1, 1) => S7 (BV6) = MK_4 (0, 1, 1, 1);
BV6 = MK_6 (1, 1, 0, 0, 0, 1) => S7 (BV6) = MK_4 (1, 0, 0, 1);
BV6 = MK_6 (1, 1, 0, 0, 1, 1) => S7 (BV6) = MK_4 (0, 1, 0, 1);
BV6 = MK_6 (1, 1, 0, 1, 0, 1) => S7 (BV6) = MK_4 (0, 0, 0, 0);
BV6 = MK_6 (1, 1, 0, 1, 1, 1) => S7 (BV6) = MK_4 (1, 1, 1, 1);
BV6 = MK_6 (1, 1, 1, 0, 0, 1) => S7 (BV6) = MK_4 (1, 1, 1, 0);
BV6 = MK_6 (1, 1, 1, 0, 1, 1) => S7 (BV6) = MK_4 (0, 0, 1, 0);
BV6 = MK_6 (1, 1, 1, 1, 0, 1) => S7 (BV6) = MK_4 (0, 0, 1, 1);
BV6 = MK_6 (1, 1, 1, 1, 1, 1) => S7 (BV6) = MK_4 (1, 1, 0, 0);
ofsort BIT4
BV6 = MK_6 (0, 0, 0, 0, 0, 0) => S8 (BV6) = MK_4 (1, 1, 0, 1);
BV6 = MK_6 (0, 0, 0, 0, 1, 0) => S8 (BV6) = MK_4 (0, 0, 1, 0);
BV6 = MK_6 (0, 0, 0, 1, 0, 0) => S8 (BV6) = MK_4 (1, 0, 0, 0);
BV6 = MK_6 (0, 0, 0, 1, 1, 0) => S8 (BV6) = MK_4 (0, 1, 0, 0);
BV6 = MK_6 (0, 0, 1, 0, 0, 0) => S8 (BV6) = MK_4 (0, 1, 1, 0);
BV6 = MK_6 (0, 0, 1, 0, 1, 0) => S8 (BV6) = MK_4 (1, 1, 1, 1);
BV6 = MK_6 (0, 0, 1, 1, 0, 0) => S8 (BV6) = MK_4 (1, 0, 1, 1);
BV6 = MK_6 (0, 0, 1, 1, 1, 0) => S8 (BV6) = MK_4 (0, 0, 0, 1);
BV6 = MK_6 (0, 1, 0, 0, 0, 0) => S8 (BV6) = MK_4 (1, 0, 1, 0);
BV6 = MK_6 (0, 1, 0, 0, 1, 0) => S8 (BV6) = MK_4 (1, 0, 0, 1);
BV6 = MK_6 (0, 1, 0, 1, 0, 0) => S8 (BV6) = MK_4 (0, 0, 1, 1);
BV6 = MK_6 (0, 1, 0, 1, 1, 0) => S8 (BV6) = MK_4 (1, 1, 1, 0);
BV6 = MK_6 (0, 1, 1, 0, 0, 0) => S8 (BV6) = MK_4 (0, 1, 0, 1);
BV6 = MK_6 (0, 1, 1, 0, 1, 0) => S8 (BV6) = MK_4 (0, 0, 0, 0);
BV6 = MK_6 (0, 1, 1, 1, 0, 0) => S8 (BV6) = MK_4 (1, 1, 0, 0);
BV6 = MK_6 (0, 1, 1, 1, 1, 0) => S8 (BV6) = MK_4 (0, 1, 1, 1);
BV6 = MK_6 (0, 0, 0, 0, 0, 1) => S8 (BV6) = MK_4 (0, 0, 0, 1);
BV6 = MK_6 (0, 0, 0, 0, 1, 1) => S8 (BV6) = MK_4 (1, 1, 1, 1);
BV6 = MK_6 (0, 0, 0, 1, 0, 1) => S8 (BV6) = MK_4 (1, 1, 0, 1);
BV6 = MK_6 (0, 0, 0, 1, 1, 1) => S8 (BV6) = MK_4 (1, 0, 0, 0);
BV6 = MK_6 (0, 0, 1, 0, 0, 1) => S8 (BV6) = MK_4 (1, 0, 1, 0);
BV6 = MK_6 (0, 0, 1, 0, 1, 1) => S8 (BV6) = MK_4 (0, 0, 1, 1);
BV6 = MK_6 (0, 0, 1, 1, 0, 1) => S8 (BV6) = MK_4 (0, 1, 1, 1);
BV6 = MK_6 (0, 0, 1, 1, 1, 1) => S8 (BV6) = MK_4 (0, 1, 0, 0);
BV6 = MK_6 (0, 1, 0, 0, 0, 1) => S8 (BV6) = MK_4 (1, 1, 0, 0);
BV6 = MK_6 (0, 1, 0, 0, 1, 1) => S8 (BV6) = MK_4 (0, 1, 0, 1);
BV6 = MK_6 (0, 1, 0, 1, 0, 1) => S8 (BV6) = MK_4 (0, 1, 1, 0);
BV6 = MK_6 (0, 1, 0, 1, 1, 1) => S8 (BV6) = MK_4 (1, 0, 1, 1);
BV6 = MK_6 (0, 1, 1, 0, 0, 1) => S8 (BV6) = MK_4 (0, 0, 0, 0);
BV6 = MK_6 (0, 1, 1, 0, 1, 1) => S8 (BV6) = MK_4 (1, 1, 1, 0);
BV6 = MK_6 (0, 1, 1, 1, 0, 1) => S8 (BV6) = MK_4 (1, 0, 0, 1);
BV6 = MK_6 (0, 1, 1, 1, 1, 1) => S8 (BV6) = MK_4 (0, 0, 1, 0);
BV6 = MK_6 (1, 0, 0, 0, 0, 0) => S8 (BV6) = MK_4 (0, 1, 1, 1);
BV6 = MK_6 (1, 0, 0, 0, 1, 0) => S8 (BV6) = MK_4 (1, 0, 1, 1);
BV6 = MK_6 (1, 0, 0, 1, 0, 0) => S8 (BV6) = MK_4 (0, 1, 0, 0);
BV6 = MK_6 (1, 0, 0, 1, 1, 0) => S8 (BV6) = MK_4 (0, 0, 0, 1);
BV6 = MK_6 (1, 0, 1, 0, 0, 0) => S8 (BV6) = MK_4 (1, 0, 0, 1);
BV6 = MK_6 (1, 0, 1, 0, 1, 0) => S8 (BV6) = MK_4 (1, 1, 0, 0);
BV6 = MK_6 (1, 0, 1, 1, 0, 0) => S8 (BV6) = MK_4 (1, 1, 1, 0);
BV6 = MK_6 (1, 0, 1, 1, 1, 0) => S8 (BV6) = MK_4 (0, 0, 1, 0);

```

```

BV6 = MK_6 (1, 1, 0, 0, 0, 0) => S8 (BV6) = MK_4 (0, 0, 0, 0);
BV6 = MK_6 (1, 1, 0, 0, 1, 0) => S8 (BV6) = MK_4 (0, 1, 1, 0);
BV6 = MK_6 (1, 1, 0, 1, 0, 0) => S8 (BV6) = MK_4 (1, 0, 1, 0);
BV6 = MK_6 (1, 1, 0, 1, 1, 0) => S8 (BV6) = MK_4 (1, 1, 0, 1);
BV6 = MK_6 (1, 1, 1, 0, 0, 0) => S8 (BV6) = MK_4 (1, 1, 1, 1);
BV6 = MK_6 (1, 1, 1, 0, 1, 0) => S8 (BV6) = MK_4 (0, 0, 1, 1);
BV6 = MK_6 (1, 1, 1, 1, 0, 0) => S8 (BV6) = MK_4 (0, 1, 0, 1);
BV6 = MK_6 (1, 1, 1, 1, 1, 0) => S8 (BV6) = MK_4 (1, 0, 0, 0);
BV6 = MK_6 (1, 0, 0, 0, 0, 1) => S8 (BV6) = MK_4 (0, 0, 1, 0);
BV6 = MK_6 (1, 0, 0, 0, 1, 1) => S8 (BV6) = MK_4 (0, 0, 0, 1);
BV6 = MK_6 (1, 0, 0, 1, 0, 1) => S8 (BV6) = MK_4 (1, 1, 1, 0);
BV6 = MK_6 (1, 0, 0, 1, 1, 1) => S8 (BV6) = MK_4 (0, 1, 1, 1);
BV6 = MK_6 (1, 0, 1, 0, 0, 1) => S8 (BV6) = MK_4 (0, 1, 0, 0);
BV6 = MK_6 (1, 0, 1, 0, 1, 1) => S8 (BV6) = MK_4 (1, 0, 1, 0);
BV6 = MK_6 (1, 0, 1, 1, 0, 1) => S8 (BV6) = MK_4 (1, 0, 0, 0);
BV6 = MK_6 (1, 0, 1, 1, 1, 1) => S8 (BV6) = MK_4 (1, 1, 0, 1);
BV6 = MK_6 (1, 1, 0, 0, 0, 1) => S8 (BV6) = MK_4 (1, 1, 1, 1);
BV6 = MK_6 (1, 1, 0, 0, 1, 1) => S8 (BV6) = MK_4 (1, 1, 0, 0);
BV6 = MK_6 (1, 1, 0, 1, 0, 1) => S8 (BV6) = MK_4 (1, 0, 0, 1);
BV6 = MK_6 (1, 1, 0, 1, 1, 1) => S8 (BV6) = MK_4 (0, 0, 0, 0);
BV6 = MK_6 (1, 1, 1, 0, 0, 1) => S8 (BV6) = MK_4 (0, 0, 1, 1);
BV6 = MK_6 (1, 1, 1, 0, 1, 1) => S8 (BV6) = MK_4 (0, 1, 0, 1);
BV6 = MK_6 (1, 1, 1, 1, 0, 1) => S8 (BV6) = MK_4 (0, 1, 1, 0);
BV6 = MK_6 (1, 1, 1, 1, 1, 1) => S8 (BV6) = MK_4 (1, 0, 1, 1);

```

endtype

B.6 Library CONTROLLER

Process CONTROLLER is responsible for the generation of the appropriate commands to the shift register of the key path as well as the four multiplexers of the data and key paths. It consists of a parallel composition of six processes: one process per controlled block (multiplexer or shift register) plus a process counting the iterations.

```

process CONTROLLER [CRYPT,
                  CTRL_CL, CTRL_CR,
                  CTRL_CK, CTRL_SHIFT, CTRL_DK] : noexit :=
  hide CS in
    CTRL_MUX_LR [CS, CTRL_CL]
    |[CS]|
    CTRL_MUX_LR [CS, CTRL_CR]
    |[CS]|
    CTRL_MUX_K [CS, CTRL_CK]
    |[CS]|
    CTRL_SHIFT [CRYPT, CS, CTRL_SHIFT]
    |[CS]|
    CTRL_DMUX_K [CS, CTRL_DK]
    |[CS]|
    COUNTER [CS] (0 of ITERATION)
endproc

```

```
(* ----- *)
(* COUNTER counts the iterations *)
```

```
process COUNTER [CS] (IT:ITERATION) : noexit :=
  CS !IT;
  COUNTER [CS] (NEXT (IT))
endproc
```

```
(* ----- *)
(* CTRL_MUX_LR generates 1 F, then 14 Ns, and finally 1 L to control one
 * of the two multiplexers in the data path *)
```

```
process CTRL_MUX_LR [CS, CTRL] : noexit :=
  CS ?IT:ITERATION;
  CTRL !MUX_DATA(IT);
  CTRL_MUX_LR [CS, CTRL]
endproc
```

```
(* ----- *)
(* CTRL_MUX_K generates 1 F and 15 N to control the key path multiplexer *)
```

```
process CTRL_MUX_K [CS, CTRL] : noexit :=
  CS ?IT:ITERATION;
  (
    [ not (LAST (IT))] ->
      CTRL !MUX_K(IT);
      CTRL_MUX_K [CS, CTRL]
    []
    [LAST (IT)] ->
      CTRL_MUX_K [CS, CTRL]
  )
endproc
```

```
(* ----- *)
(* CTRL_SHIFT controls the shift register *)
```

```
process CTRL_SHIFT [CRYPT, CS, CTRL] : noexit :=
  CRYPT ?CRYPT:BOOL;
  CTRL_SHIFT_LOOP [CRYPT, CS, CTRL] (CRYPT)
where
  process CTRL_SHIFT_LOOP [CRYPT, CS, CTRL] (CRYPT:BOOL) : noexit :=
    CS ?IT:ITERATION;
    (
      [ not (LAST (IT))] ->
        CTRL !SHIFT_CODE (IT, CRYPT);
        CTRL_SHIFT_LOOP [CRYPT, CS, CTRL] (CRYPT)
      []
      [LAST (IT)] ->
        CTRL_SHIFT [CRYPT, CS, CTRL]
    )
  endproc
endproc
```

(* _____ *)
 (* CTRL_DMUX_K generates 15 N and 1 L to control the double multiplexer *)

```

process CTRL_DMUX_K [CS, CTRL] : noexit :=
  CS ?IT:ITERATION;
  (
    [ not (LAST (IT))] ->
      CTRL !DMUX_K(IT);
      CTRL_DMUX_K [CS, CTRL]
    []
    [LAST (IT)] ->
      CTRL_DMUX_K [CS, CTRL]
  )
endproc

```

B.7 Library KEY_PATH

Process KEY_PATH describes the architecture of the key path, generating the sixteen subkeys required for the sixteen iterations.

```

process KEY_PATH [KEY, SUBKEY, CTRL_CK, CTRL_SHIFT, CTRL_DK] : noexit :=
  hide FIRST_K, INTERMEDIATE_K in
  PC1 [KEY, FIRST_K]
  |[FIRST_K]|
  (
    (
      hide K, KKK, SK in
      (
        SHIFT_REGISTER [CTRL_SHIFT, K, SK]
        |[SK]|
        DUPLICATE_K [CTRL_DK, SK, INTERMEDIATE_K, KKK]
      )
      |[K, KKK]|
      CHOOSE_K [CTRL_CK, FIRST_K, KKK, K]
    )
    |[INTERMEDIATE_K]|
    PC2 [INTERMEDIATE_K, SUBKEY]
  )

```

where

(* _____ *)
 (* PC1 breaks the initial 64 bit key into a 56-bit vector *)

```

process PC1 [KEY, FIRST_K] : noexit :=
  KEY ?K64:BIT64;
  FIRST_K !PC1(K64);
  PC1 [KEY, FIRST_K]
endproc

```

```
(* ----- *)
(* SHIFT_REGISTER performs, depending on the iteration, one or two shifts
 * to the left or right shift(s) of a 56 bit word *)
```

```
process SHIFT_REGISTER [CTRL, INPUT, OUTPUT] : noexit :=
  (
    CTRL ?CTRL:SHIFT;
      exit (CTRL, any BIT56)
    |||
    INPUT ?I56:BIT56;
      exit (any SHIFT, I56)
  )
>> accept CTRL : SHIFT, I56 : BIT56 in
  (
    [CTRL = NO] ->
      OUTPUT !I56;
        SHIFT_REGISTER [CTRL, INPUT, OUTPUT]
    []
    [CTRL = LS1] ->
      OUTPUT !LSHIFT(I56);
        SHIFT_REGISTER [CTRL, INPUT, OUTPUT]
    []
    [CTRL = LS2] ->
      OUTPUT !LSHIFT(LSHIFT(I56));
        SHIFT_REGISTER [CTRL, INPUT, OUTPUT]
    []
    [CTRL = RS1] ->
      OUTPUT !RSHIFT(I56);
        SHIFT_REGISTER [CTRL, INPUT, OUTPUT]
    []
    [CTRL = RS2] ->
      OUTPUT !RSHIFT(RSHIFT(I56));
        SHIFT_REGISTER [CTRL, INPUT, OUTPUT]
  )
endproc
```

```
(* ----- *)
(* CHOOSE_K closes the loop in the key path, by redirecting the input on
 * INPUT to OUTPUT, but for the first iteration where the original key is
 * read on FIRST_IN *)
```

```
process CHOOSE_K [CTRL, FIRST_IN, INPUT, OUTPUT] : noexit :=
  CTRL ?CTRL:PHASE;
  (
    [CTRL = F] ->
      FIRST_IN ?I56:BIT56;
        OUTPUT_K [CTRL, FIRST_IN, INPUT, OUTPUT] (I56)
    []
    [CTRL = N] ->
      INPUT ?I56:BIT56;
        OUTPUT_K [CTRL, FIRST_IN, INPUT, OUTPUT] (I56)
  )
```

```

    )
  where
    process OUTPUT_K [CTRL, FIRST_IN, INPUT, OUTPUT]
      (B56 : BIT56) : noexit :=
        OUTPUT !B56;
        CHOOSE_K [CTRL, FIRST_IN, INPUT, OUTPUT]
    endproc
  endproc

(* ----- *)
(* DUPLICATE_K reads a 56-bit vector from INPUT and outputs it to OUTPUT1
 * and OUTPUT2, but for the last iteration, where it outputs only to
 * OUTPUT1 *)

  process DUPLICATE_K [CTRL, INPUT, OUTPUT1, OUTPUT2] : noexit :=
    (
      CTRL ?CTRL:PHASE;
      exit (CTRL, any BIT56)
      |||
      INPUT ?I56:BIT56;
      exit (any PHASE, I56)
    )
  >> accept CTRL : PHASE, I56 : BIT56 in
    (
      [CTRL = N] ->
        (
          (
            OUTPUT1 !I56;
            exit
            |||
            OUTPUT2 !I56;
            exit
          )
          >>
          DUPLICATE_K [CTRL, INPUT, OUTPUT1, OUTPUT2]
        )
      []
      [CTRL = L] ->
        OUTPUT1 !I56;
        DUPLICATE_K [CTRL, INPUT, OUTPUT1, OUTPUT2]
    )
  endproc

(* ----- *)
(* PC2 applies PC2 to generate the current sub key *)

  process PC2 [KK, SUBKEY] : noexit :=
    KK ?I56:BIT56;
    SUBKEY !PC2(I56);
    PC2 [KK, SUBKEY]
  endproc

```

endproc

(* _____ *)

B.8 Library CIPHER

The processes of library CIPHER.lib implement Figure 2 of the standard [17], i.e., they compute

$$P(S_i(E(R_i) + K_i))$$

where K_i is the i -th subkey and R_i is the 32-bit vector handled by the i -th iteration of the DES.

```

process CIPHER [K, R, PX] : noexit :=
  hide ER,
    IS1, IS2, IS3, IS4, IS5, IS6, IS7, IS8,
    SO1, SO2, SO3, SO4, SO5, SO6, SO7, SO8
  in
    (
      E [R, ER]
      |[ER]|
      XOR_48 [ER, K, IS1, IS2, IS3, IS4, IS5, IS6, IS7, IS8]
    )
    |[IS1, IS2, IS3, IS4, IS5, IS6, IS7, IS8]|
    (
      S1 [IS1, SO1]
      |||
      S2 [IS2, SO2]
      |||
      S3 [IS3, SO3]
      |||
      S4 [IS4, SO4]
      |||
      S5 [IS5, SO5]
      |||
      S6 [IS6, SO6]
      |||
      S7 [IS7, SO7]
      |||
      S8 [IS8, SO8]
    )
    |[SO1, SO2, SO3, SO4, SO5, SO6, SO7, SO8]|
    P [SO1, SO2, SO3, SO4, SO5, SO6, SO7, SO8, PX]

```

where

(* _____ *)

(* *E expands a 32-bit word to 48-bits using function E* *)

```

process E [INPUT, OUTPUT] : noexit :=
  INPUT ?I32:BIT32;

```



```

        OUTPUT !E(I32);
        E [INPUT, OUTPUT]
    endproc

(* ----- *)
(* XOR_48 asynchronously reads two 48-bit vectors and output the bitwise
 * sum, splitted into eight 6-bit vectors *)

process XOR_48 [A, B, R1, R2, R3, R4, R5, R6, R7, R8] : noexit :=
    (
        A ? A48 : BIT48;
            exit (A48, any BIT48)
        |||
        B ? B48 : BIT48;
            exit (any BIT48, B48)
    )
    >> accept A48, B48 : BIT48 in
        SPLIT [A, B, R1, R2, R3, R4, R5, R6, R7, R8] (XOR (A48, B48))
where
    (* the auxiliary process factors the computation of XOR (A48, B48) *)
    process SPLIT [A, B, R1, R2, R3, R4, R5, R6, R7, R8]
        (I48 : BIT48) : noexit :=
        (
            R1 ! (1TO6 (I48)); exit
            |||
            R2 ! (7TO12 (I48)); exit
            |||
            R3 ! (13TO18 (I48)); exit
            |||
            R4 ! (19TO24 (I48)); exit
            |||
            R5 ! (25TO30 (I48)); exit
            |||
            R6 ! (31TO36 (I48)); exit
            |||
            R7 ! (37TO42 (I48)); exit
            |||
            R8 ! (43TO48 (I48)); exit
        )
        >>
        XOR_48 [A, B, R1, R2, R3, R4, R5, R6, R7, R8]
    endproc
endproc

(* ----- *)

process S1 [INPUT, OUTPUT] : noexit :=
    INPUT ?I6:BIT6;
        OUTPUT !S1(I6);
        S1 [INPUT, OUTPUT]
endproc

```

(* ----- *)

```
process S2 [INPUT, OUTPUT] : noexit :=  
  INPUT ?I6:BIT6;  
  OUTPUT !S2(I6);  
  S2 [INPUT, OUTPUT]  
endproc
```

(* ----- *)

```
process S3 [INPUT, OUTPUT] : noexit :=  
  INPUT ?I6:BIT6;  
  OUTPUT !S3(I6);  
  S3 [INPUT, OUTPUT]  
endproc
```

(* ----- *)

```
process S4 [INPUT, OUTPUT] : noexit :=  
  INPUT ?I6:BIT6;  
  OUTPUT !S4(I6);  
  S4 [INPUT, OUTPUT]  
endproc
```

(* ----- *)

```
process S5 [INPUT, OUTPUT] : noexit :=  
  INPUT ?I6:BIT6;  
  OUTPUT !S5(I6);  
  S5 [INPUT, OUTPUT]  
endproc
```

(* ----- *)

```
process S6 [INPUT, OUTPUT] : noexit :=  
  INPUT ?I6:BIT6;  
  OUTPUT !S6(I6);  
  S6 [INPUT, OUTPUT]  
endproc
```

(* ----- *)

```
process S7 [INPUT, OUTPUT] : noexit :=  
  INPUT ?I6:BIT6;  
  OUTPUT !S7(I6);  
  S7 [INPUT, OUTPUT]  
endproc
```

(* ----- *)

```
process S8 [INPUT, OUTPUT] : noexit :=  
  INPUT ?I6:BIT6;
```

```

    OUTPUT !S8(I6);
    S8 [INPUT, OUTPUT]
endproc

```

```

(* ----- *)
(* P collects the results of the eight processes S_BOX_i (on INi) and
* outputs them in a single transition exit; the permutation P is applied
* in a second step when outputting the result on OUTPUT.
*
* the additional transition with gate exit could be removed by applying
* the permutation P in a subsequent process, namely XOR_32 *)

```

```

process P [IN1, IN2, IN3, IN4, IN5, IN6, IN7, IN8, OUTPUT] : noexit :=
(
  IN1 ?I1:BIT4;
  exit (I1, any BIT4, any BIT4, any BIT4,
        any BIT4, any BIT4, any BIT4, any BIT4)
  |||
  IN2 ?I2:BIT4;
  exit (any BIT4, I2, any BIT4, any BIT4,
        any BIT4, any BIT4, any BIT4, any BIT4)
  |||
  IN3 ?I3:BIT4;
  exit (any BIT4, any BIT4, I3, any BIT4,
        any BIT4, any BIT4, any BIT4, any BIT4)
  |||
  IN4 ?I4:BIT4;
  exit (any BIT4, any BIT4, any BIT4, I4,
        any BIT4, any BIT4, any BIT4, any BIT4)
  |||
  IN5 ?I5:BIT4;
  exit (any BIT4, any BIT4, any BIT4, any BIT4,
        I5, any BIT4, any BIT4, any BIT4)
  |||
  IN6 ?I6:BIT4;
  exit (any BIT4, any BIT4, any BIT4, any BIT4,
        any BIT4, I6, any BIT4, any BIT4)
  |||
  IN7 ?I7:BIT4;
  exit (any BIT4, any BIT4, any BIT4, any BIT4,
        any BIT4, any BIT4, I7, any BIT4)
  |||
  IN8 ?I8:BIT4;
  exit (any BIT4, any BIT4, any BIT4, any BIT4,
        any BIT4, any BIT4, any BIT4, I8)
)
>> accept I1 : BIT4, I2 : BIT4, I3 : BIT4, I4 : BIT4,
      I5 : BIT4, I6 : BIT4, I7 : BIT4, I8 : BIT4 in
OUTPUT !P(MK_32(I1, I2, I3, I4, I5, I6, I7, I8));
P [IN1, IN2, IN3, IN4, IN5, IN6, IN7, IN8, OUTPUT]
endproc

```

endproc

B.9 Library DATA_PATH

This library defines the process DATA_PATH, performing the 16 iterations of the DES, outputting on gate OUTPUT the result of (de)ciphering the data read on gate DATA using the sequence of 16 subkeys received on gate SUBKEY.

```

process DATA_PATH [DATA, OUTPUT, SUBKEY, CTRL_CL, CTRL_CR] : noexit :=
  hide FIRST_L, FIRST_R, OUTPUT_L, OUTPUT_R in
  (
    IP [DATA, FIRST_L, FIRST_R]
    |[FIRST_L, FIRST_R]|
    (
      hide CL_XR, CR_FX, FX_XR, XR_CR, CR_CL in
      (
        CHOOSE_L [CTRL_CL, FIRST_L, CR_CL, CL_XR, OUTPUT_L]
        |[CR_CL]|
        CHOOSE_R [CTRL_CR, FIRST_R, XR_CR, CR_CL, CR_FX,
                  OUTPUT_R]
      )
      |[CL_XR, CR_FX, XR_CR]|
      CIPHER [SUBKEY, CR_FX, FX_XR]
      |[FX_XR]|
      XOR_32 [CL_XR, FX_XR, XR_CR]
    )
  )
  |[OUTPUT_L, OUTPUT_R]|
  IIP [OUTPUT_L, OUTPUT_R, OUTPUT]
where

(* ----- *)
(* IP applies the initial permutation IP to the initial 64-bit vector
 * received on gate DATA and breaks the resulting 64-bit vector into two
 * 32-bit vectors L and R *)

process IP [DATA, FIRST_L, FIRST_R] : noexit :=
  DATA ?164:BIT64;
  SPLIT_LR [DATA, FIRST_L, FIRST_R] (IP (164))
where
  (* the auxiliary process avoids to compute IP (164) twice *)
  process SPLIT_LR [DATA, FIRST_L, FIRST_R] (B64 : BIT64) : noexit :=
  (
    FIRST_L !1TO32(B64);
    exit
    |||
    FIRST_R !33TO64(B64);
    exit
  )
  >> IP [DATA, FIRST_L, FIRST_R]

```

endproc
endproc

(* ----- *)
 (* *CHOOSE_L* reads a 32-bit vector from *INPUT* and outputs to *OUTPUT*, but for
 * the first iteration, where it reads from *FIRST_IN*, and the last
 * iteration, where it outputs to *LAST_OUT* *)

```

process CHOOSE_L [CTRL, FIRST_IN, INPUT, OUTPUT, LAST_OUT] : noexit :=
  CTRL ?CTRL:PHASE;
  (
    [CTRL = F] ->
      FIRST_IN ?L32:BIT32;
      OUTPUT !L32;
      CHOOSE_L [CTRL, FIRST_IN, INPUT, OUTPUT, LAST_OUT]
    []
    [CTRL = N] ->
      INPUT ?L32:BIT32;
      OUTPUT !L32;
      CHOOSE_L [CTRL, FIRST_IN, INPUT, OUTPUT, LAST_OUT]
    []
    [CTRL = L] ->
      INPUT ?L32:BIT32;
      LAST_OUT !L32;
      CHOOSE_L [CTRL, FIRST_IN, INPUT, OUTPUT, LAST_OUT]
  )
endproc

```

(* ----- *)
 (* *CHOOSE_R* reads a 32-bit vector from *INPUT* and outputs to *OUT1* and *OUT2*,
 * but for the first iteration, where it reads from *FIRST_IN*, and the last
 * one, where it outputs to *LAST_OUT* *)

```

process CHOOSE_R [CTRL, FIRST_IN, INPUT, OUT1, OUT2, LAST_OUT]
  : noexit :=
  CTRL ?CTRL:PHASE;
  (
    [CTRL = F] ->
      FIRST_IN ?R32:BIT32;
      OUTPUT_R [CTRL, FIRST_IN, INPUT, OUT1, OUT2, LAST_OUT]
      (R32)
    []
    [CTRL = N] ->
      INPUT ?R32:BIT32;
      OUTPUT_R [CTRL, FIRST_IN, INPUT, OUT1, OUT2, LAST_OUT]
      (R32)
    []
    [CTRL = L] ->
      INPUT ?R32:BIT32;
      LAST_OUT !R32;
      CHOOSE_R [CTRL, FIRST_IN, INPUT, OUT1, OUT2,
      LAST_OUT]
  )

```

```

    )
where
    process OUTPUT_R [CTRL, FIRST_IN, INPUT, OUT1, OUT2, LAST_OUT]
        (R32 : BIT32) : noexit :=
        OUT1 !R32;
        OUT2 !R32;
        CHOOSE_R [CTRL, FIRST_IN, INPUT, OUT1, OUT2, LAST_OUT]
        []
        OUT2 !R32;
        OUT1 !R32;
        CHOOSE_R [CTRL, FIRST_IN, INPUT, OUT1, OUT2, LAST_OUT]
    endproc
endproc

(* ----- *)
(* XOR_32 reads two 32-bit vectors and outputs their bitwise sum *)

process XOR_32 [A, B, R] : noexit :=
    (
        A ? A32 : BIT32;
        exit (A32, any BIT32)
        |||
        B ? B32 : BIT32;
        exit (any BIT32, B32)
    )
    >> accept A32, B32 : BIT32 in
    R ! XOR (A32, B32);
    XOR_32 [A, B, R]
endproc

(* ----- *)
(* IIP assembles the two 32-bit vectors computed by the algorithm to the 64
 * bit vector and applies the inverse initial permutation IIP to compute
 * the final result *)

process IIP [OUTPUT_L, OUTPUT_R, OUTPUT] : noexit :=
    (
        OUTPUT_L ?OL:BIT32;
        exit (OL, any BIT32)
        |||
        OUTPUT_R ?OH:BIT32;
        exit (any BIT32, OH)
    )
    >> accept OL, OH : BIT32 in
    OUTPUT !IIP(MK_64(OH,OL));
    IIP [OUTPUT_L, OUTPUT_R, OUTPUT]
endproc

endproc

```

B.10 Library DES

The library DES.lib factorizes the definition of the architecture of the asynchronous DES, and is shared by all three LOTOS specifications of the DES, namely DES_ABSTRACT.lotos, DES_CONCRETE.lotos, and DES_SAMPLE.lotos.

```

process DES [CRYPT, KEY, DATA, OUTPUT] : noexit :=
  hide SUBKEY, CTRL_CL, CTRL_CR, CTRL_CK, CTRL_SHIFT, CTRL_DK in
    (
      DATA_PATH [DATA, OUTPUT, SUBKEY, CTRL_CL, CTRL_CR]
      |[SUBKEY]|
      KEY_PATH [KEY, SUBKEY, CTRL_CK, CTRL_SHIFT, CTRL_DK]
    )
    |[CTRL_CL, CTRL_CR, CTRL_CK, CTRL_SHIFT, CTRL_DK]|
    CONTROLLER [CRYPT, CTRL_CL, CTRL_CR, CTRL_CK, CTRL_SHIFT, CTRL_DK]
endproc

```

B.11 Specification with Abstract Bits: DES_ABSTRACT

This LOTOS specification can be used for compositional state space generation and verification. Due to the abstraction, there is no need to close the system with an environment.

```

specification DES_ABSTRACT [CRYPT, KEY, DATA, OUTPUT] : noexit

```

```

  library
    BOOLEAN, NATURAL, BIT_ABSTRACT, TYPES,
    PERMUTATION_FUNCTIONS, S_BOX_FUNCTIONS
  endlib

```

```

behaviour

```

```

  DES [CRYPT, KEY, DATA, OUTPUT]

```

```

where

```

```

  library
    DES, CONTROLLER, KEY_PATH, DATA_PATH, CIPHER
  endlib

```

```

endspec

```

B.12 Specification with Concrete Bits: DES_CONCRETE

This LOTOS specification can be used to generate a prototype implementation. It is not suitable for state space generation, because it would have to enumerate over all possible input values, i.e., 64-bit vectors.

```

specification DES_CONCRETE [CRYPT, KEY, DATA, OUTPUT] : noexit

```

```

  library
    BOOLEAN, NATURAL, BIT_CONCRETE, TYPES,
    PERMUTATION_FUNCTIONS, S_BOX_FUNCTIONS

```

endlib

behaviour

DES [CRYPT, KEY, DATA, OUTPUT]

where

library

DES, CONTROLLER, KEY_PATH, DATA_PATH, CIPHER

endlib

endspec

B.13 Specification with Concrete Bits and Environment: DES_SAMPLE

This LOTOS specification can be used to directly (i.e., non compositionally) generate an LTS. After hiding all offers and minimization for branching bisimulation, the generated LTS is the one shown in Figure 2.

specification DES_SAMPLE [CRYPT, KEY, DATA, OUTPUT] : **noexit**

library

BOOLEAN, NATURAL, BIT_CONCRETE, TYPES,
PERMUTATION_FUNCTIONS, S_BOX_FUNCTIONS

endlib

behaviour

DES [CRYPT, KEY, DATA, OUTPUT]
|[CRYPT, KEY, DATA, OUTPUT]|
ENVIRONMENT [CRYPT, KEY, DATA, OUTPUT]

where

library

DES, CONTROLLER, KEY_PATH, DATA_PATH, CIPHER

endlib

(* _____ *)

type CONSTANTS is BIT64

opns

(* frequently used sample data *)

C_01234567_89ABCDEF : → BIT64

(* frequently used sample key *)

C_13345779_9BBCDFF1 : → BIT64

(* result of ciphering C_01234567_89ABCDEF by C_13345779_9BBCDFF1 *)

C_85E81354_0F0AB405 : → BIT64

eqns

ofsort BIT64

```

    C_01234567_89ABCDEF =
      MK_64 (0, 0, 0, 0, 0, 0, 0, 1, 0, 0, 1, 0, 0, 0, 1, 1,
            0, 1, 0, 0, 0, 1, 0, 1, 0, 1, 1, 0, 0, 1, 1, 1,
            1, 0, 0, 0, 1, 0, 0, 1, 1, 0, 1, 0, 1, 0, 1, 0, 1, 1,
            1, 1, 0, 0, 1, 1, 0, 1, 1, 1, 1, 0, 1, 1, 1, 1);
  ofsort BIT64
    C_13345779_9BBCDFF1 =
      MK_64 (0, 0, 0, 1, 0, 0, 1, 1, 0, 0, 1, 1, 0, 1, 0, 0,
            0, 1, 0, 1, 0, 1, 1, 1, 0, 1, 1, 1, 1, 0, 0, 1,
            1, 0, 0, 1, 1, 0, 1, 1, 1, 0, 1, 1, 1, 1, 0, 0,
            1, 1, 0, 1, 1, 1, 1, 1, 1, 1, 1, 0, 0, 0, 0, 1);
  ofsort BIT64
    C_85E81354_0F0AB405 =
      MK_64 (1, 0, 0, 0, 0, 1, 0, 1, 1, 1, 1, 0, 1, 0, 0, 0,
            0, 0, 0, 1, 0, 0, 1, 1, 0, 1, 0, 1, 0, 1, 0, 0,
            0, 0, 0, 0, 1, 1, 1, 1, 0, 0, 0, 0, 1, 0, 1, 0,
            1, 0, 1, 1, 0, 1, 0, 0, 0, 0, 0, 0, 0, 1, 0, 1);
endtype

(* ----- *)
(* process simulating the environment in order to close the system,
 * executing a single encryption of c_01234567_89abcdef with
 * c_13345779_9BBCDFF1, and checking the output of the expected result *)

process ENVIRONMENT [CRYPT, KEY, DATA, OUTPUT] : noexit :=
  CRYPT !true;
  KEY !C_13345779_9BBCDFF1;
  DATA !C_01234567_89ABCDEF;
  (* cipher of C_01234567_89ABCDEF with C_13345779_9BBCDFF1 *)
  OUTPUT !C_85E81354_0F0AB405;
  stop
endproc

endspec

```

B.14 Specification of Property 4

This LOTOS specification describes an automaton, which is used to verify the correct synchronisation of the data and key paths by equivalence checking.

```

specification PROPERTY_4 [CRYPT, SUBKEY] : noexit

  library
    BOOLEAN, NATURAL
  endlib

  type T is NATURAL
    opns
      14 : -> NAT
    eqns

```

```

    ofsort NAT
      14 = SUCC (SUCC (SUCC (SUCC (SUCC (9))))))
  endtype

```

behaviour

```

(**
 * process describing a loop starting with a synchronization on gate CRYPT,
 * followed by 16 synchronizations on gate SUBKEY, where the synchronization
 * on CRYPT corresponding to the next iteration can already appear after
 * 14 synchronizations on SUBKEY.
 * this process is used to verify the presence of 16 iterations in the DES.
 *)
CRYPT;
  SIXTEEN_ITERATIONS [CRYPT, SUBKEY]

```

where

```

process SIXTEEN_ITERATIONS [CRYPT, SUBKEY] : noexit :=
  FOURTEEN_ITERATIONS [SUBKEY] (0)
  >>
  (
    SUBKEY;
    SUBKEY;
    exit
    |||
    CRYPT;
    exit
  )
  >>
  SIXTEEN_ITERATIONS [CRYPT, SUBKEY]
endproc

process FOURTEEN_ITERATIONS [SUBKEY] (N:NAT) : exit :=
  [N = 14] ->
    exit
  []
  [N < 14] ->
    SUBKEY;
    FOURTEEN_ITERATIONS [SUBKEY] (N + 1)
endproc

```

endspec**C C Code for the EXEC/CÆSAR Framework**

To generate a prototype from the LNT or LOTOS model using the EXEC/CÆSAR framework, additional C code is necessary, namely the main program (for which the example provided with CADP¹³ can

¹³Precisely, the file \$CADP/src/exec_caesar/main.c included in the CADP toolbox.

be used) and so-called *gate functions* implementing the interaction with the environment. The DES prototype reads its inputs from the standard input and prints its results to the standard output. Each rendezvous corresponds to one line of input (respectively, output), following the syntax of LOTOS, i.e., “G !O”, where G is a gate name and O is a sequence of characters corresponding to the offer. For convenience, 64-bit vectors (for gates CRYPT, DATA, KEY, and OUTPUT) are represented by a sequence of sixteen hexadecimal digits, and Booleans (for gate CRYPT) by 0 (false) and 1 (true). The prototype can also write its execution trace in the SEQ format¹⁴ to a log file.

C.1 Auxiliary Functions for Reading and Writing

The following auxiliary functions are required to parse and print 64-bit vectors. Each line of input parsed is stored in a variable (local to the module defining the gate functions), because the first gate function called by the prototype might not correspond to the input line, enabling its reuse by another gate function.

```

/* ----- */
#include "caesar_kernel.h"

extern void CAESAR_KERNEL_EXIT();

#define streq(S1,S2) (strcmp ((S1), (S2)) == 0)

/* ----- */
/* auxiliary function to convert a hexadecimal digit into a 4-bit vector */

static ADT_BIT4 CHAR_TO_BIT4 (C)
char C;
{
    switch (C) {
        case '0':
            return MK_4 (BIT_ZERO (), BIT_ZERO (), BIT_ZERO (), BIT_ZERO ());
        case '1':
            return MK_4 (BIT_ZERO (), BIT_ZERO (), BIT_ZERO (), BIT_ONE ());
        case '2':
            return MK_4 (BIT_ZERO (), BIT_ZERO (), BIT_ONE (), BIT_ZERO ());
        case '3':
            return MK_4 (BIT_ZERO (), BIT_ZERO (), BIT_ONE (), BIT_ONE ());
        case '4':
            return MK_4 (BIT_ZERO (), BIT_ONE (), BIT_ZERO (), BIT_ZERO ());
        case '5':
            return MK_4 (BIT_ZERO (), BIT_ONE (), BIT_ZERO (), BIT_ONE ());
        case '6':
            return MK_4 (BIT_ZERO (), BIT_ONE (), BIT_ONE (), BIT_ZERO ());
        case '7':
            return MK_4 (BIT_ZERO (), BIT_ONE (), BIT_ONE (), BIT_ONE ());
        case '8':
            return MK_4 (BIT_ONE (), BIT_ZERO (), BIT_ZERO (), BIT_ZERO ());
        case '9':

```

¹⁴<http://cadp.inria.fr/man/exhibitor.html#sect3>

```

        return MK_4 (BIT_ONE (), BIT_ZERO (), BIT_ZERO (), BIT_ONE ());
    case 'a': case 'A':
        return MK_4 (BIT_ONE (), BIT_ZERO (), BIT_ONE (), BIT_ZERO ());
    case 'b': case 'B':
        return MK_4 (BIT_ONE (), BIT_ZERO (), BIT_ONE (), BIT_ONE ());
    case 'c': case 'C':
        return MK_4 (BIT_ONE (), BIT_ONE (), BIT_ZERO (), BIT_ZERO ());
    case 'd': case 'D':
        return MK_4 (BIT_ONE (), BIT_ONE (), BIT_ZERO (), BIT_ONE ());
    case 'e': case 'E':
        return MK_4 (BIT_ONE (), BIT_ONE (), BIT_ONE (), BIT_ZERO ());
    case 'f': case 'F':
        return MK_4 (BIT_ONE (), BIT_ONE (), BIT_ONE (), BIT_ONE ());
    default:
        CAESAR_KERNEL_EXIT ("cannot convert '%c' into a 4-bit vector\n",
                            C);
        /* NOTREACHED */
        return MK_4 (BIT_ZERO (), BIT_ZERO (), BIT_ZERO (), BIT_ZERO ());
}
}

/* ----- */

/* auxiliary macro to print four bits as a hexadecimal digit */

#define PRINT_4_BITS(F, B1, B2, B3, B4) \
{ \
    char N; \
    N = 0; \
    if ((B1) == BIT_ONE ()) N += 8; \
    if ((B2) == BIT_ONE ()) N += 4; \
    if ((B3) == BIT_ONE ()) N += 2; \
    if ((B4) == BIT_ONE ()) N += 1; \
    fprintf ((F), "%x", N); \
}

/* ----- */

/* auxiliary macro to access bit number N of the 64-bit vector V */

#define BIT(V, N) (CAESAR_ADT_STAR_ADT_BIT64 (V).CAESAR_ADT_ ## N ## _MK_64)

/* ----- */

/* auxiliary function to output a 64-bit vector as 16 hexadecimal digits */

static void PRINT_64_BIT_VECTOR (F, V)
FILE *F;
ADT_BIT64 V;
{
    PRINT_4_BITS (F, BIT (V, 1), BIT (V, 2), BIT (V, 3), BIT (V, 4));
    PRINT_4_BITS (F, BIT (V, 5), BIT (V, 6), BIT (V, 7), BIT (V, 8));
}

```

```

    PRINT_4_BITS (F, BIT (V, 9), BIT (V, 10), BIT (V, 11), BIT (V, 12));
    PRINT_4_BITS (F, BIT (V, 13), BIT (V, 14), BIT (V, 15), BIT (V, 16));
    PRINT_4_BITS (F, BIT (V, 17), BIT (V, 18), BIT (V, 19), BIT (V, 20));
    PRINT_4_BITS (F, BIT (V, 21), BIT (V, 22), BIT (V, 23), BIT (V, 24));
    PRINT_4_BITS (F, BIT (V, 25), BIT (V, 26), BIT (V, 27), BIT (V, 28));
    PRINT_4_BITS (F, BIT (V, 29), BIT (V, 30), BIT (V, 31), BIT (V, 32));
    PRINT_4_BITS (F, BIT (V, 33), BIT (V, 34), BIT (V, 35), BIT (V, 36));
    PRINT_4_BITS (F, BIT (V, 37), BIT (V, 38), BIT (V, 39), BIT (V, 40));
    PRINT_4_BITS (F, BIT (V, 41), BIT (V, 42), BIT (V, 43), BIT (V, 44));
    PRINT_4_BITS (F, BIT (V, 45), BIT (V, 46), BIT (V, 47), BIT (V, 48));
    PRINT_4_BITS (F, BIT (V, 49), BIT (V, 50), BIT (V, 51), BIT (V, 52));
    PRINT_4_BITS (F, BIT (V, 53), BIT (V, 54), BIT (V, 55), BIT (V, 56));
    PRINT_4_BITS (F, BIT (V, 57), BIT (V, 58), BIT (V, 59), BIT (V, 60));
    PRINT_4_BITS (F, BIT (V, 61), BIT (V, 62), BIT (V, 63), BIT (V, 64));
}

/* ----- */

/* buffer for the gate of the rendezvous in the current line of stdin */

static char CURRENT_GATE[6];

/* buffer for the offer of the rendezvous in the current line of stdin */

static char CURRENT_OFFER[17];

/*
 * if equal to zero, CURRENT_GATE and CURRENT_OFFER contain the gate (resp.
 * OFFER) of the rendezvous in the current line of stdin
 */

static char CURRENT_LINE_NOT_READ = 1;

/* ----- */

/*
 * auxiliary function to check whether the current line of the standard
 * input corresponds to a rendezvous on gate GATE
 */

int PARSE_INPUT (GATE, OFFER)
char *GATE;
void *OFFER; /* a caster */
{
    int N;

    if (feof (stdin))
        return (0);

    if (CURRENT_LINE_NOT_READ) {
        /* read a line from stdin */
        N = scanf ("%5s_!%16[0123456789aAbBcCdDeEfF]\n" ,

```

```

        CURRENT_GATE, CURRENT_OFFER);
    if (N == EOF)
        return (0);
    if (N != 2) {
        CAESAR_KERNEL_EXIT ("incorrect_input_syntax\n");
    }
    CURRENT_LINE_NOT_READ = 0;
}
if (!streq (CURRENT_GATE, GATE))
    return (0);
CURRENT_LINE_NOT_READ = 1;

if (streq (GATE, "CRYPT")) {
    if (streq (CURRENT_OFFER, "0")) {
        *((ADT_BOOL *) OFFER) = ADT_FALSE ();
    } else if (streq (CURRENT_OFFER, "1")) {
        *((ADT_BOOL *) OFFER) = ADT_TRUE ();
    } else {
        CAESAR_KERNEL_EXIT ("incorrect_offer_\"%s\"_for_gate_%s\n",
            CURRENT_OFFER, GATE);
        /* NOTREACHED */
    }
} else if (streq (GATE, "DATA") || streq (GATE, "KEY")) {
    /* set remaining digits to '0' */
    for (N = strlen (CURRENT_OFFER) ; N < 16 ; N++)
        CURRENT_OFFER[N] = '0';
    /* concatenation of the 16 characters to form a 64-bit vector */
    *((ADT_BIT64 *) OFFER) =
        CONCAT_BIT4 (CHAR_TO_BIT4 (CURRENT_OFFER[0]),
            CHAR_TO_BIT4 (CURRENT_OFFER[1]),
            CHAR_TO_BIT4 (CURRENT_OFFER[2]),
            CHAR_TO_BIT4 (CURRENT_OFFER[3]),
            CHAR_TO_BIT4 (CURRENT_OFFER[4]),
            CHAR_TO_BIT4 (CURRENT_OFFER[5]),
            CHAR_TO_BIT4 (CURRENT_OFFER[6]),
            CHAR_TO_BIT4 (CURRENT_OFFER[7]),
            CHAR_TO_BIT4 (CURRENT_OFFER[8]),
            CHAR_TO_BIT4 (CURRENT_OFFER[9]),
            CHAR_TO_BIT4 (CURRENT_OFFER[10]),
            CHAR_TO_BIT4 (CURRENT_OFFER[11]),
            CHAR_TO_BIT4 (CURRENT_OFFER[12]),
            CHAR_TO_BIT4 (CURRENT_OFFER[13]),
            CHAR_TO_BIT4 (CURRENT_OFFER[14]),
            CHAR_TO_BIT4 (CURRENT_OFFER[15]));
} else {
    CAESAR_KERNEL_EXIT ("unknown_gate_\"%s\"_\"n\" , CURRENT_GATE);
    /* NOTREACHED */
}
return (1);
}

```

C.2 Gate Functions

Lines typeset in *small, light grey font* correspond to automatically generated code to check assumptions about the parameters of gate functions and (possibly) log gate function calls to a file. These functions are documented in the header file `caesar_kernel.h` included in the CADP toolbox.

```

/* ----- */

int CRYPT (INPUT_MODE, BOOL, OFFER, EOL)
CAESAR_KERNEL_OFFER INPUT_MODE;
char *BOOL;
ADT_BOOL *OFFER;
CAESAR_KERNEL_OFFER EOL;
{
    int CAESAR_STATUS;

    CAESAR_KERNEL_ASSERT_INPUT (INPUT_MODE);
    CAESAR_KERNEL_ASSERT_TYPE (BOOL, "ADT_BOOL");
    CAESAR_KERNEL_ASSERT_EOL (EOL);

    CAESAR_STATUS = PARSE_INPUT ("CRYPT", OFFER);

    CAESAR_KERNEL_LOG_GATE ( __func__ );
    /* LINTED */
    CAESAR_KERNEL_LOG_OFFER (INPUT_MODE, BOOL, *OFFER, ADT_PRINT_BOOL,
                             CAESAR_STATUS);
    CAESAR_KERNEL_LOG_RESULT (CAESAR_STATUS);

    return (CAESAR_STATUS);
}

/* ----- */

int DATA (INPUT_MODE, BIT64, OFFER, EOL)
CAESAR_KERNEL_OFFER INPUT_MODE;
char *BIT64;
ADT_BIT64 *OFFER;
CAESAR_KERNEL_OFFER EOL;
{
    int CAESAR_STATUS;

    CAESAR_KERNEL_ASSERT_INPUT (INPUT_MODE);
    CAESAR_KERNEL_ASSERT_TYPE (BIT64, "ADT_BIT64");
    CAESAR_KERNEL_ASSERT_EOL (EOL);

    CAESAR_STATUS = PARSE_INPUT ("DATA", OFFER);

    CAESAR_KERNEL_LOG_GATE ( __func__ );
    /* LINTED */
    CAESAR_KERNEL_LOG_OFFER (INPUT_MODE, BIT64, *OFFER, ADT_PRINT_BIT64,
                             CAESAR_STATUS);
    CAESAR_KERNEL_LOG_RESULT (CAESAR_STATUS);
}

```

```

    return (CAESAR_STATUS);
}

/* ----- */

int KEY (INPUT_MODE, BIT64, OFFER, EOL)
CAESAR_KERNEL_OFFER INPUT_MODE;
char *BIT64;
ADT_BIT64 *OFFER;
CAESAR_KERNEL_OFFER EOL;
{
    int CAESAR_STATUS;

    CAESAR_KERNEL_ASSERT_INPUT (INPUT_MODE);
    CAESAR_KERNEL_ASSERT_TYPE (BIT64, "ADT_BIT64");
    CAESAR_KERNEL_ASSERT_EOL (EOL);

    CAESAR_STATUS = PARSE_INPUT ("KEY", OFFER);

    CAESAR_KERNEL_LOG_GATE (--func--);
    /* LINTED */
    CAESAR_KERNEL_LOG_OFFER (INPUT_MODE, BIT64, *OFFER, ADT_PRINT_BIT64,
                             CAESAR_STATUS);
    CAESAR_KERNEL_LOG_RESULT (CAESAR_STATUS);

    return (CAESAR_STATUS);
}

/* ----- */

int OUTPUT (OUTPUT_MODE, BIT64, OFFER, EOL)
CAESAR_KERNEL_OFFER OUTPUT_MODE;
char *BIT64;
ADT_BIT64 OFFER;
CAESAR_KERNEL_OFFER EOL;
{
    CAESAR_KERNEL_ASSERT_OUTPUT (OUTPUT_MODE);
    CAESAR_KERNEL_ASSERT_TYPE (BIT64, "ADT_BIT64");
    CAESAR_KERNEL_ASSERT_EOL (EOL);

    fprintf (stdout, "OUTPUT_!");
    PRINT_64_BIT_VECTOR (stdout, OFFER);
    fprintf (stdout, "\n");

    CAESAR_KERNEL_LOG_GATE (--func--);
    /* LINTED */
    CAESAR_KERNEL_LOG_OFFER (OUTPUT_MODE, BIT64, OFFER, ADT_PRINT_BIT64,
                             1);
    CAESAR_KERNEL_LOG_RESULT (1);

    return (1);
}

```

}

/* _____ */

D Complete Verification Scenarios for the Asynchronous DES

The complete verification scenario of the asynchronous DES is executed by the following SVL script, using only sequential tools of CADP (i.e., no distributed state space generation is required¹⁵). The script is also available in the demo example on the CADP website⁴.

The SVL script first compositionally generates the LTS corresponding to the abstract LNT model DES_ABSTRACT.lnt. The script then verifies several properties of the LNT models, using different techniques, such as model checking (for the temporal logic properties of Sections 4 and 5) and equivalence checking, but also the generation of a prototype from the LNT model DES_CONCRETE.lnt and comparing its output for some example data and key with official results. These first steps can be easily adapted to use the LOTOS model instead of the LNT model. Finally, the LNT models are compared (using equivalence checking) with the corresponding LOTOS specifications, which are supposed to be located in a subdirectory called “LOTOS”, together with an SVL script called “demo.svl” generating the LTSs for the LOTOS specifications DES_ABSTRACT.lotos and DES_SAMPLE.lotos.

For a description of the syntax of SVL, see the SVL manual page¹⁶ — the most important points being that lines starting with “%” are Bourne shell commands, and that temporal logic formulas in MCL (Model Checking Language) [14] are directly inlined.

— *Compositional state space generation*

— *In order to reduce the time and memory requirements for the generation of the state space and the verification of properties of the model, the domain of 64-bit vectors is reduced to a single value, by simply redefining the data type for bits so as to use a singleton domain: instead of the module "BIT_CONCRETE.lnt", the module "BIT_ABSTRACT.lnt" is used.*

— *Each of the three main components of the DES is generated and minimized under the constraints of the already computed parts.*

```
% DEFAULT_PROCESS_FILE="DES.lnt"
```

— *creation of BIT.lnt as a copy of BIT_ABSTRACT.lnt*

```
% sed -e 's/BIT_ABSTRACT/BIT/' BIT_ABSTRACT.lnt > BIT.lnt
```

```
% SVL_RECORD_FOR_CLEAN "BIT.lnt"
```

— *generation and minimization of the controller*

¹⁵The screenshots used in the manual page of the DISTRIBUTOR tool were obtained by the distributed generation of DES_SAMPLE.lotos

¹⁶<http://cadp.inria.fr/man/svl.html>

```
"controller.bcg" = branching reduction of
    CONTROLLER;
```

*— generation and minimization of the key-path, constrained by the
— controller generated before*

```
"keypath.bcg" = branching reduction of
    KEY_PATH
    -|[CTRL_CK, CTRL_SHIFT, CTRL_DK]|
    "controller.bcg";
```

*— generation and minimization of the parallel composition of the
— minimized controller and the minimized key-path*

```
"controller_keypath.bcg" = branching reduction of
    "keypath.bcg"
    |[CTRL_CK, CTRL_SHIFT, CTRL_DK]|
    "controller.bcg";
```

*— generation and minimization of the data-path, constrained by the
— parallel composition of the controller and key-path*

```
"data_path.bcg" = branching reduction of
    DATA_PATH
    -|[CTRL_CL, CTRL_CR, SUBKEY]|
    "controller_keypath.bcg";
```

*— generation and minimization of the complete DES with abstract bits;
— gate SUBKEY is left visible for verification purposes*

```
"des.bcg" = branching reduction of
    hide CTRL_CL, CTRL_CR, CTRL_CK, CTRL_SHIFT, CTRL_DK in
        "data_path.bcg"
        |[CTRL_CL, CTRL_CR, SUBKEY]|
        "controller_keypath.bcg";
```

— Verification of properties

```
property PROPERTY_1
    "The_DES_executes_indefinitely , i.e. , has_no_deadlock"
is
    deadlock of "des.bcg";
    expected FALSE;
end property
```

```
property PROPERTY_2
    "The_DES_can_always_deliver_outputs , and_each_triplet_of_inputs_is"
```

```

" eventually_followed_by_an_output"
is
" des.bcg" |= with evaluator4
    library standard.mcl end_library
    [ true* ] INEVITABLE ( { OUTPUT ... } );
expected TRUE;

" des.bcg" |= with evaluator4
    library standard.mcl end_library
    macro SEQUENCE (A, B, C) is
        (A) .
        not ((A) or (B) or (C))* .
        (B) .
        not ((A) or (B) or (C))* .
        (C)
    end_macro
    macro PARALLEL (A, B, C) is
        SEQUENCE ((A), (B), (C)) |
        SEQUENCE ((A), (C), (B)) |
        SEQUENCE ((B), (A), (C)) |
        SEQUENCE ((B), (C), (A)) |
        SEQUENCE ((C), (A), (B)) |
        SEQUENCE ((C), (B), (A))
    end_macro
    [ true* . PARALLEL ({CRYPT...}, {DATA...}, {KEY...}) ]
    INEVITABLE ({OUTPUT...});
expected TRUE;
end property

```

```

property PROPERTY_3 (A, B, N)
    " The_DES_accepts_up_to_$N, but_not_more, successive_transitions"
    "\" $A\" before_producing_a_transition \"$B\""
is
    " des.bcg"
    |= with evaluator4
        [ true* . ( ($A) . not ( ($A) or ($B) )* ){$N} . ($A) ]
        false;
    expected TRUE;

    " des.bcg"
    |= with evaluator4
        < true* . ( ($A) . not ( ($A) or ($B) )* ){$N-1} . ($A) >
        true;
    expected TRUE;
end property

check PROPERTY_3 (" {CRYPT...}" , " {OUTPUT...}" , 3);
check PROPERTY_3 (" {DATA...}" , " {OUTPUT...}" , 3);
check PROPERTY_3 (" {KEY...}" , " {OUTPUT...}" , 4);

```

```

property PROPERTY_4
  "The DES correctly synchronizes the data and key paths: there are"
  "16 iterations, each marked by a transition labeled with gate"
  "SUBKEY"
is
  — The presence of the 16 iterations in "des.bcg" can be verified
  — by comparison with an LTS describing the cyclic execution of a
  — CRYPT transition followed by sixteen SUBKEY transitions. Because
  — this LTS has only two actions ("CRYPT" and "SUBKEY", without
  — offers), in "des.bcg", the labels for these two gates have to be
  — renamed, all other labels have to be hidden, and the comparison
  — has to use a weak equivalence (here, branching bisimulation).

  "des_crypt_subkey.bcg" =
    branching reduction of
    total rename "CRYPT.*" → CRYPT, "SUBKEY.*" → SUBKEY in
    hide DATA, OUTPUT, KEY in "des.bcg";

  — verification by equivalence checking

  branching comparison "property_4.lnt" == "des_crypt_subkey.bcg";
  expected TRUE;

  — verification by model checking

  "des_crypt_subkey.bcg" |= with evaluator4
    macro SIXTEEN_SUBKEYS_ONE_CRYPT () is
      for l : Nat from 1 to 14 do "SUBKEY" end for .
      (
        ( "SUBKEY" . ( ( "SUBKEY" . "CRYPT" ) |
                       ( "CRYPT" . "SUBKEY" ) ) ) |
        ( "CRYPT" . "SUBKEY" . "SUBKEY" )
      )
    end_macro
    ( [ true ]
      nu X . ( ( < SIXTEEN_SUBKEYS_ONE_CRYPT () > true )
              and
              ( [ SIXTEEN_SUBKEYS_ONE_CRYPT () ] X ) ) )
    and
    ( < CRYPT > true )
    and
    ( [ not CRYPT ] false );
  expected TRUE;
end property

```

— *To verify the correct function, a prototype implementation is generated*
 — *from the LNT specification "DES.lnt" (with concrete bits) using the*
 — *EXEC/CAESAR framework. This prototype is then used to encipher and*

— decipher some sample blocks, and the results are compared to the
 — official results.

```
% SVL_PRINT_MESSAGE ""
```

```
% SVL_PRINT_MESSAGE "generating DES executable..."
```

— creation of BIT.lnt as a copy of BIT-CONCRETE.lnt

```
% sed -e 's/BIT-CONCRETE/BIT/' BIT-CONCRETE.lnt > BIT.lnt
```

— translation from LNT to LOTOS

```
"DES.lotos" = "DES.lnt";
```

— translation from LOTOS to C

```
% caesar.adt -silent DES.lotos 2>&1 | tee -a $SVL_LOG_FILE
```

```
% caesar -silent -exec -e7 DES.lotos 2>&1 | tee -a $SVL_LOG_FILE
```

— compilation of the generated C code

```
% $CADP/src/com/cadp_cc -I$CADP/incl -DCAESAR_KERNEL_DELAY=0 -DLNT \
```

```
%   DES.c gate_functions.c $CADP/src/exec-caesar/main.c -lm \
```

```
%   -o des 2>&1 | tee -a $SVL_LOG_FILE
```

— cleanup of generated files

```
% SVL_CLEAN_LNT_DEPEND "DES.lnt"
```

```
% SVL_REMOVE "DES.h"
```

```
% SVL_REMOVE "DES.c"
```

```
% SVL_REMOVE "DES.err"
```

```
% SVL_REMOVE "DES.o"
```

```
% SVL_REMOVE "gate_functions.o"
```

```
% SVL_REMOVE "main.o"
```

```
% SVL_RECORD_FOR_CLEAN "des"
```

```
% SVL_RECORD_FOR_CLEAN "input.log"
```

```
property PROPERTY_5 (CRYPT, KEY, DATA, OUTPUT)
```

```
    "The DES prototype computes the expected result"
```

```
is
```

```
    % echo "CRYPT_!$CRYPT" > input.log
```

```
    % echo "DATA_!$DATA" >> input.log
```

```
    % echo "KEY_!$KEY" >> input.log
```

```
    % ./des < input.log
```

```
    expected "OUTPUT_!$OUTPUT";
```

```
end property
```

```
check PROPERTY_5 (1, "8000000000000000", "8000000000000000",  
    "6a7fc86c02379a5e");
```

```
check PROPERTY_5 (0, "8000000000000000", "6a7fc86c02379a5e",
```

```

    "8000000000000000");
check PROPERTY_5 (1, "133457799bbcdff1", "0123456789abcdef",
    "85e813540f0ab405");
check PROPERTY_5 (0, "133457799bbcdff1", "0123456789abcdef",
    "ee0f7c12e0b09338");
check PROPERTY_5 (1, "133457799bbcdff1", "ee0f7c12e0b09338",
    "0123456789abcdef");
check PROPERTY_5 (0, "133457799bbcdff1", "85e813540f0ab405",
    "0123456789abcdef");
check PROPERTY_5 (1, "0e329232ea6d0d73", "8787878787878787",
    "0000000000000000");
check PROPERTY_5 (0, "0e329232ea6d0d73", "0000000000000000",
    "8787878787878787");

```

```

property PROPERTY_6
  "The_DES_(with_concrete_bits)_correctly_computes_the_encryption"
  "result_of_data_0123456789ABCDEF_with_key_133457799BBCDFF1;"
  "moreover,_when_value_offers_are_removed_from_action_labels,_the"
  "LTS_generated_from_the_DES_with_concrete_bits_is_included,_modulo"
  "branching_preorder,_in_the_LTS_generated_from_the_DES_with"
  "abstract_bits"
is
  "des_sample.bcg" = branching reduction of
    "DES_SAMPLE.Int":"MAIN_SAMPLE";

  "des_sample.bcg" |= with evaluator4
    library standard.mcl end_library
    [ not ( { OUTPUT ... } ) * ] INEVITABLE ( { OUTPUT ... } );
expected TRUE;

  branching comparison
    total rename
      "CRYPT.*" → "CRYPT",
      "DATA.*" → "DATA",
      "KEY.*" → "KEY",
      "OUTPUT.*" → "OUTPUT"
    in "des_sample.bcg"
  <=
    hide SUBKEY in
    total rename
      "CRYPT.*" → "CRYPT",
      "DATA.*" → "DATA",
      "KEY.*" → "KEY",
      "OUTPUT.*" → "OUTPUT"
    in "des.bcg";
expected TRUE;
end property

```

```
property PROPERTY_7
  "equivalence between the LNT and LOTOS models"
is
  -- build the LTSs from the LOTOS specifications
  % ( cd LOTOS ; echo "" ; svl )

  -- comparison of the LTSs generated with abstract bits
  branching comparison
    "des.bcg"
    ==
    "LOTOS/des.bcg" ;
  expected TRUE ;

  -- comparison of the LTSs generated with concrete bits
  % if [ -f LOTOS/des_sample.bcg ]
  % then
    branching comparison
      "des_sample.bcg"
      ==
      "LOTOS/des_sample.bcg" ;
    expected TRUE ;
  % fi
end property
```
